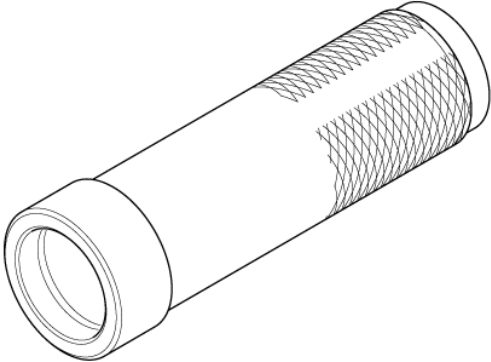
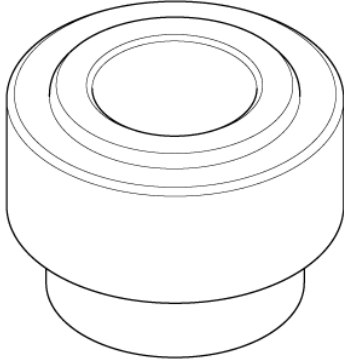

**M/T Countershaft Disassembly, Reassembly, and Inspection****Special Tool Required**

Image	Description/Tool Number
	Driver Handle, 40 mm I.D. 07746-0030100
	Bearing Driver Attachment, 30 mm I.D. 07746-0030300

**Disassembly****Disassembly**

NOTE: Refer to the Exploded View as needed during this procedure.

**1. M/T Change Lever Assembly**

1. Remove the interlock bolt (A).
2. Remove any old liquid gasket from the interlock bolt.
3. Remove the change lever assembly (B).
4. Remove the 8 x 14 mm dowel pins (C).

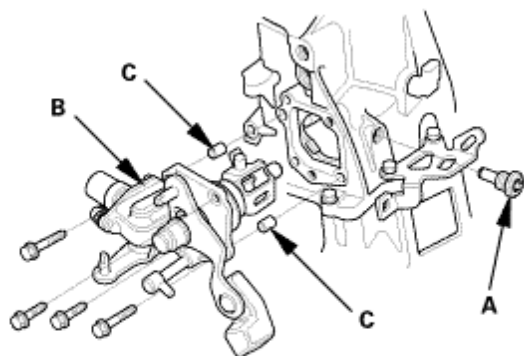

## 2. Back-Up Light Switch

1. Remove the back-up light switch (A).
2. Remove any old liquid gasket.

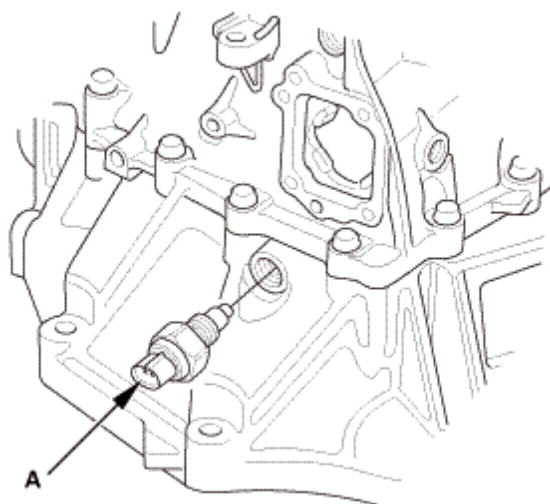

## 3. Output Shaft (Countershaft) Speed Sensor

1. Remove the output shaft (countershaft) speed sensor (A), the plain washer (B), and the O-ring (C).

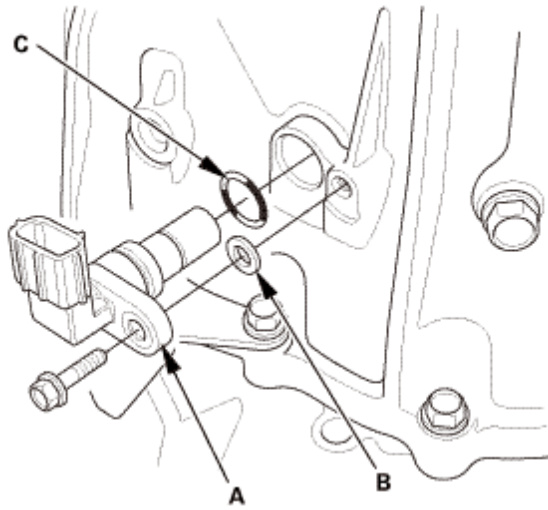

#### 4. Transmission Housing

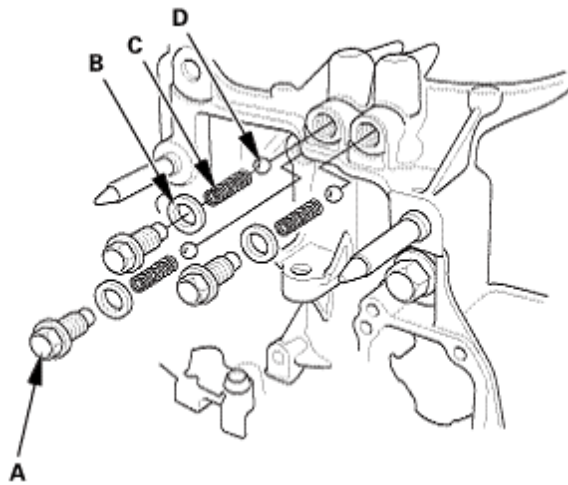

1. Remove the detent bolts (A), the 12 mm sealing washers (B), the detent ball springs (C), and the steel balls (D).

2. Remove the 10 mm flange bolt (A) and the sealing washer (B).

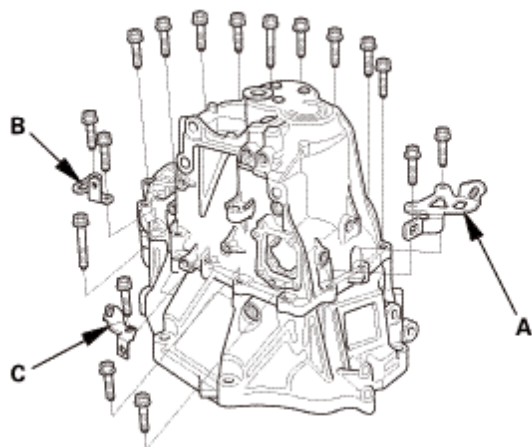
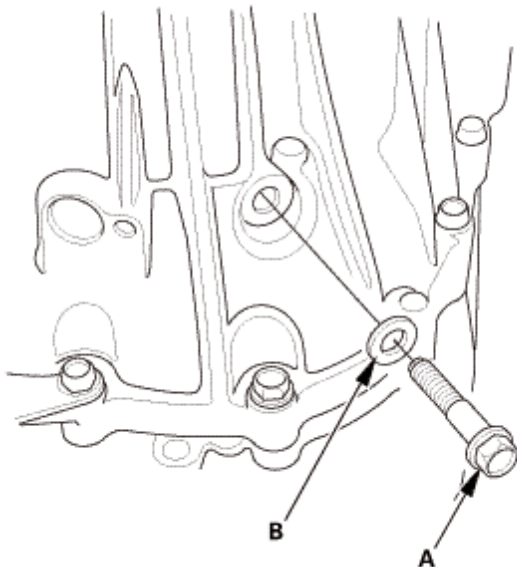

3. Loosen the 8 mm flange bolts in a crisscross pattern in several steps, then remove them with transmission hanger A, transmission hanger B, and the harness bracket (C).

4. Remove the 32 mm sealing cap (A).
5. While expanding the 72 mm snap ring (B) on the countershaft ball bearing with snap ring pliers, lift the transmission housing (C).
6. Release the snap ring pliers, and remove the transmission housing.
7. Remove the 14 x 20 mm dowel pins (D).

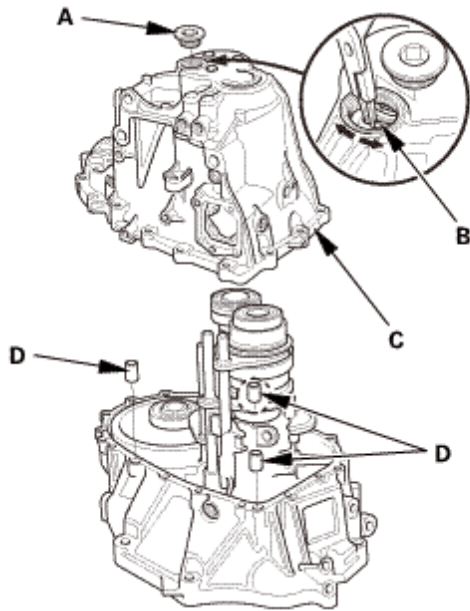

**5. Reverse Shift Fork**

1. Remove the reverse shift fork (A).

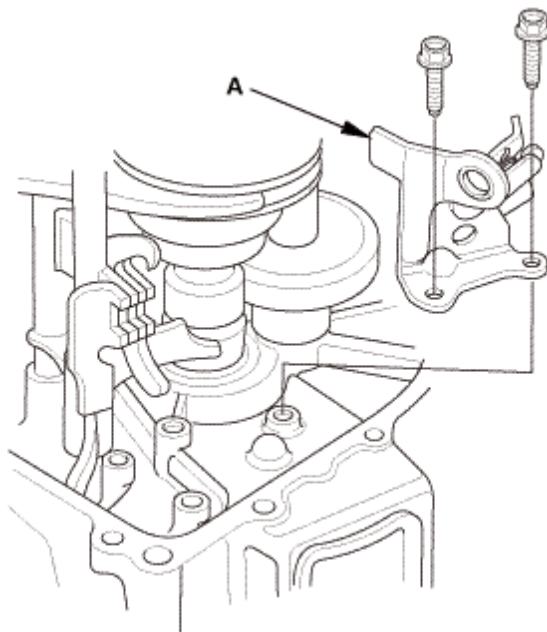

**6. Baffle Plate**

1. Remove the baffle plate (A).

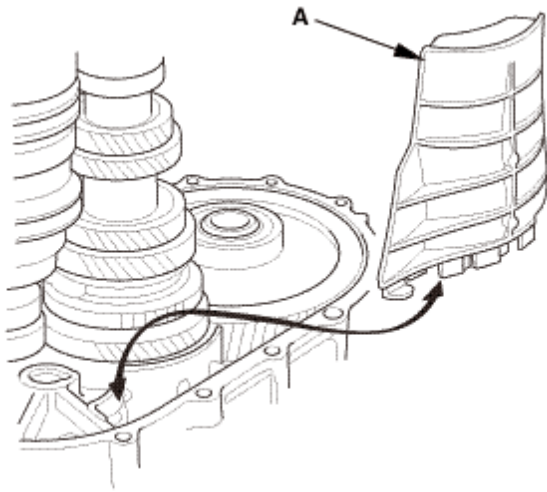

### 7. Reverse Idler Gear

1. Remove the reverse idler gear (A) and the reverse idler gear shaft (B).

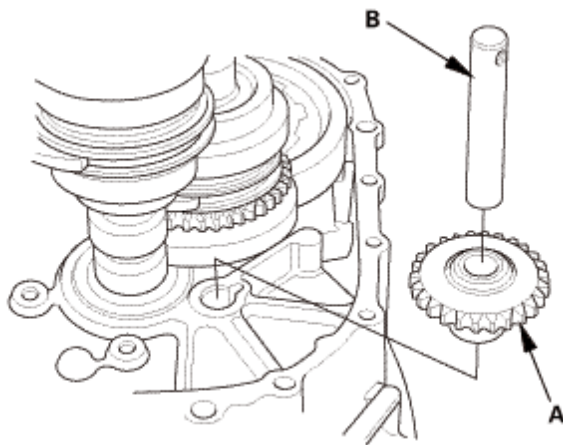

### 8. M/T Mainshaft and Countershaft and Shift Fork Assembly

1. Apply a thin layer of tape to the mainshaft splines to protect the seal.  
  
NOTE: Do not apply too much tape as it will damage the oil seal.
2. Remove the mainshaft assembly (A) and the countershaft assembly (B) with the shift fork assembly (C) from the clutch housing (D).
3. Remove the 28 mm washer (E).
4. Remove the 28 mm spring washer (F).

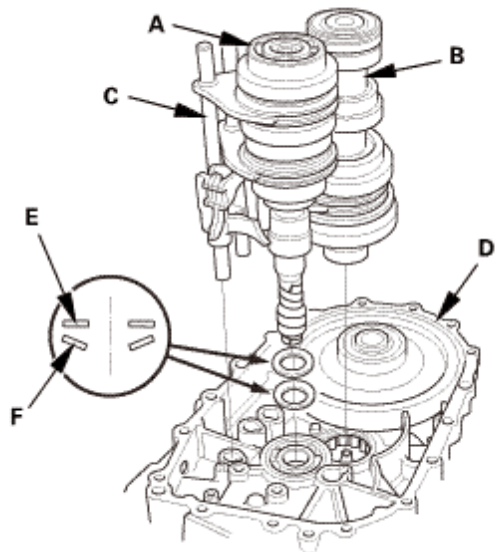

### 9. M/T Countershaft

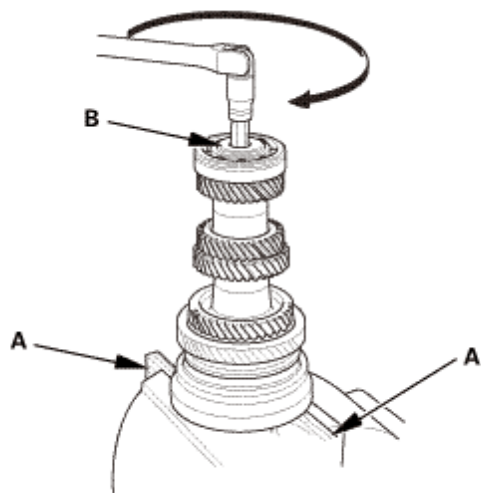

1. Securely clamp the countershaft assembly in a bench vise with wood blocks (A).
2. Remove the special bolt (B) (left-hand threads).

- 
3. Support 6th gear (A) on steel blocks (B).
  4. Use a press (C) and an attachment (D) to press the countershaft out of the ball bearing and 6th gear.
  5. Remove the 35 mm shim.

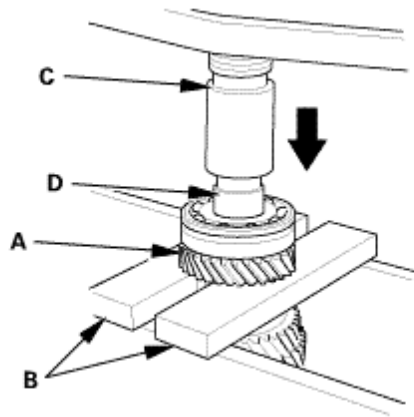

6. Support 4th gear (A) on steel blocks (B).

7. Use the press (C) and an attachment (D) to press the countershaft (E) out of 4th gear and 5th gear.

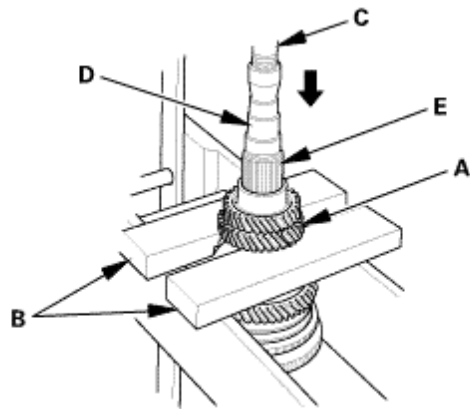

8. Support 2nd gear (A) on steel blocks (B).

9. Use the press (C) and an attachment (D) to press the countershaft (E) out of 2nd gear and 3rd gear.

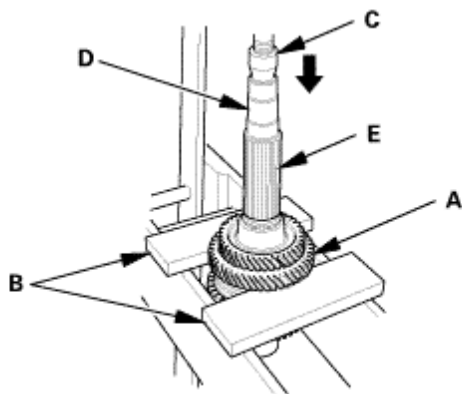

**Inspection**

**Inspection**

### 1. M/T Countershaft Inspection



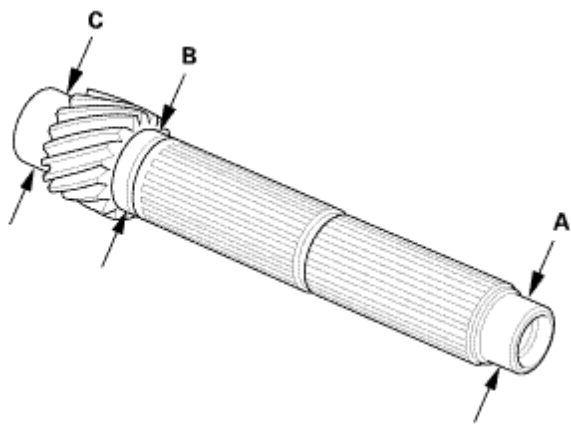

1. Inspect the gear and bearing contact areas for wear and damage.
2. Measure the countershaft at points A, B, and C. If any part of the countershaft is less than the service limit, replace it.

**Standard:****A Ball Bearing Contact Area (Transmission Housing Side):**

30.020 – 30.033 mm (1.18189 – 1.18240 in)

**B 1st Gear Distance Collar Contact Area:**

39.937 – 39.950 mm (1.57232 – 1.57283 in)

**C Needle Bearing Contact Area (Clutch Housing Side):**

35.000 – 35.015 mm (1.37795 – 1.37854 in)

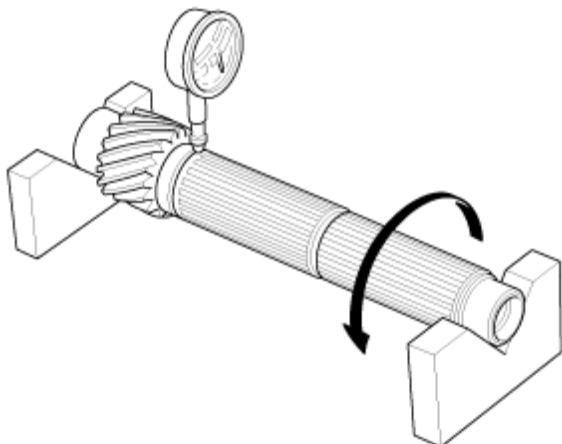
**Service Limit:****A: 30.020 mm (1.18189 in)****B: 39.937 mm (1.57232 in)****C: 35.000 mm (1.37795 in)**

3. Inspect the runout by supporting both ends of the countershaft.
4. Rotate the countershaft two complete turns while measuring with a dial gauge. If the runout exceeds the standard, replace the countershaft.

**Standard:****0.02 mm  
(0.0008 in) max.****Exploded View****View****1. M/T Countershaft Exploded View****Exploded View**

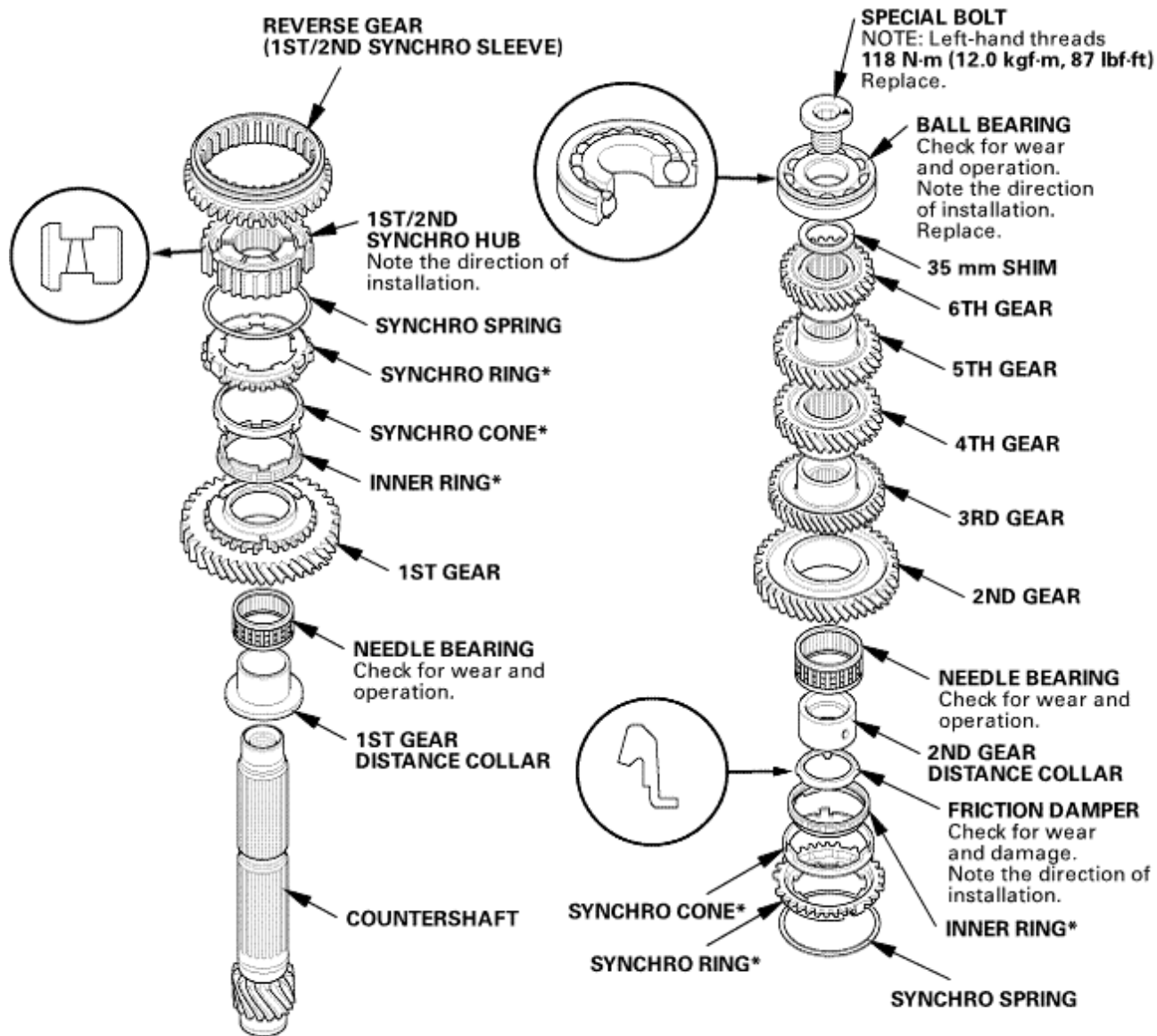

\*:The components of the triple cone synchro assembly.

**Reassembly**

NOTE: Refer to the Exploded View as needed during this procedure.

1. M/T Countershaft

1. Clean all parts in solvent, dry them, and apply MTF to all contact surfaces.
2. Install the 1st gear distance collar (A).
3. Install the needle bearing (B).
4. Install 1st gear (C).

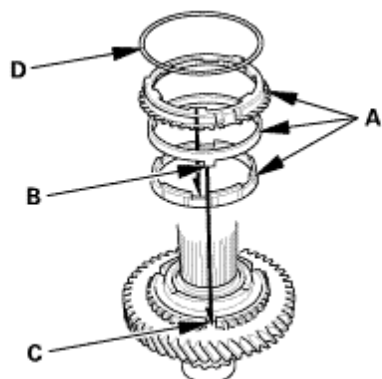
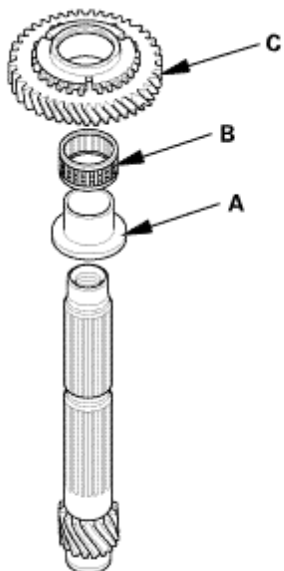

5. Install the triple cone synchro assembly (A) by aligning the synchro cone fingers (B) with the grooves (C) in 1st gear.

6. Install the synchro spring (D).

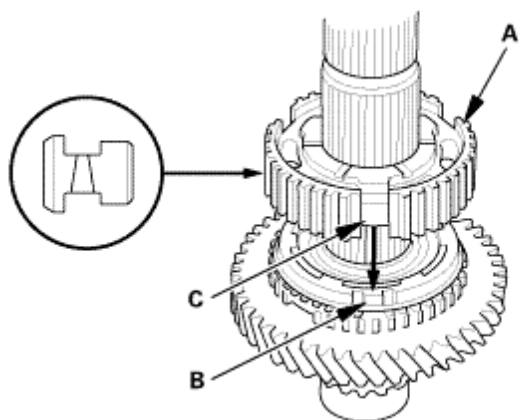

7. Install the 1st/2nd synchro hub (A) by aligning the synchro ring fingers (B) with the grooves (C) in the 1st/2nd synchro hub.

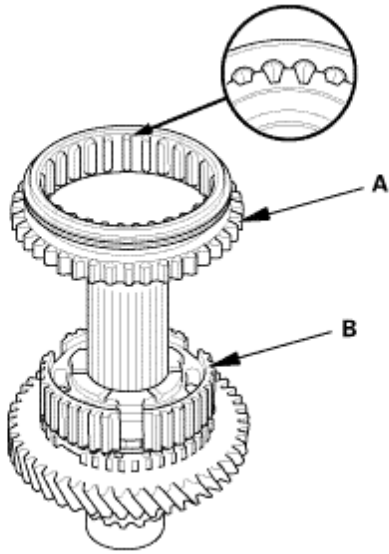

8. Install the reverse gear (A) by aligning the slots of the reverse gear and the 1st/2nd synchro hub (B).

NOTE: Make sure to align the slots in the 1st/2nd synchro hub as shown.

9. Check the operation of the 1st/2nd synchro hub set.

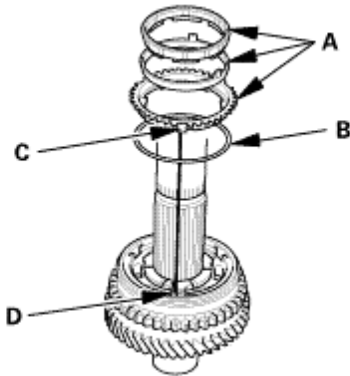

10. Install the triple cone synchro assembly (A) with the synchro spring (B) by aligning the synchro ring fingers (C) with the grooves (D) in the 1st/2nd synchro hub.

11. Install the friction damper (A) to the 2nd gear distance collar (B).

12. Install the 2nd gear distance collar and the friction damper by aligning the friction damper fingers (C) with the grooves (D) in the 1st/2nd synchro hub.

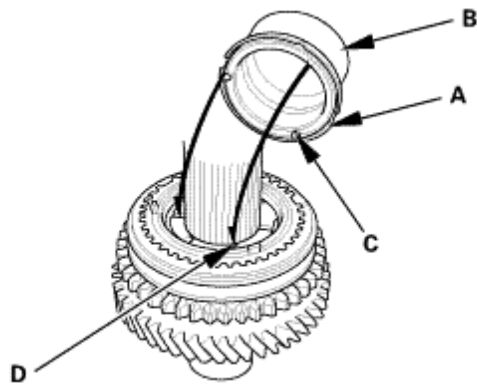

13. Install the needle bearing (A).

14. Install 2nd gear (B) by aligning the synchro cone fingers (C) with the grooves (D) in 2nd gear.

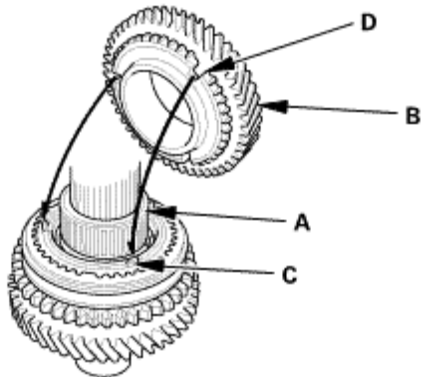

15. Support the countershaft (A) on steel blocks.

16. Press on 3rd gear (B) using the 40 mm I.D. driver handle and a press (C).

NOTE: Do not exceed the maximum pressure.

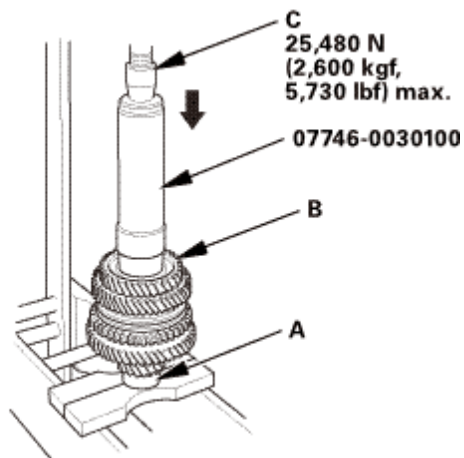

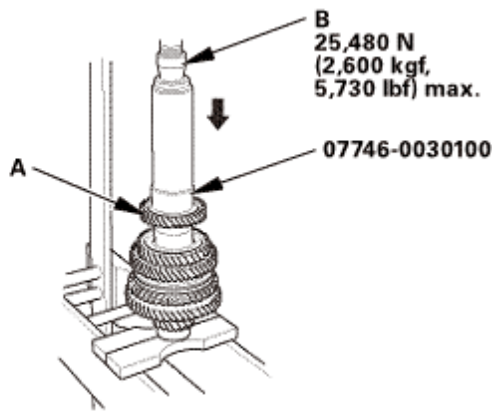

17. Press on 4th gear (A) using the 40 mm I.D. driver handle and the press (B).

NOTE: Do not exceed the maximum pressure.

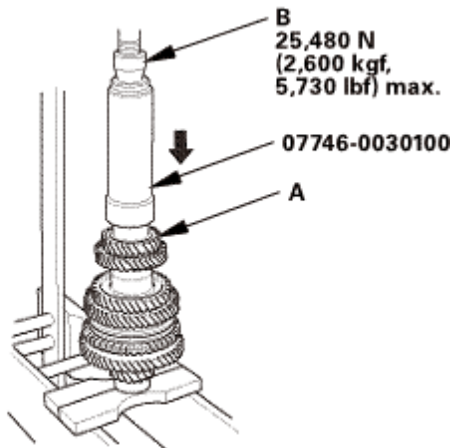

18. Press on 5th gear (A) using the 40 mm I.D. driver handle and the press (B).

NOTE: Do not exceed the maximum pressure.

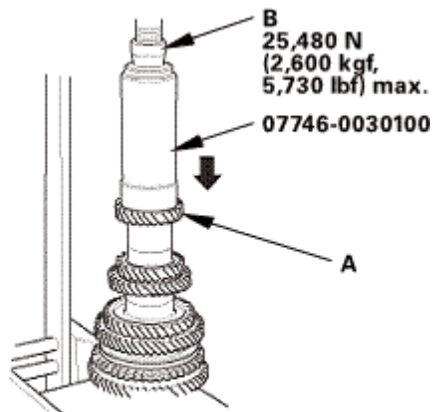

19. Press on 6th gear (A) using the 40 mm I.D. driver handle and the press (B).

NOTE: Do not exceed the maximum pressure.

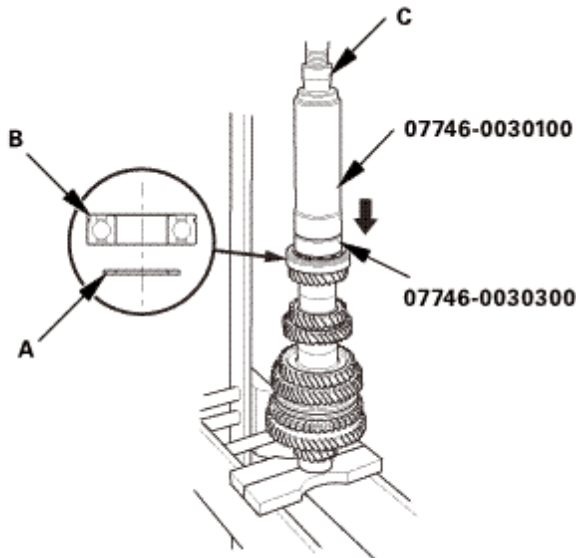

20. Install the 35 mm shim (A).

21. Temporarily press on the used ball bearing (B) using the 40 mm I.D. driver handle, the 30 mm I.D. bearing driver attachment, and the press (C).

**NOTE:**

- Use any size of 35 mm shim, and note size you used. Measurements taken in the following steps will determine the correct shim to use for final assembly.
- Make sure the ball bearing is installed in the correct direction.

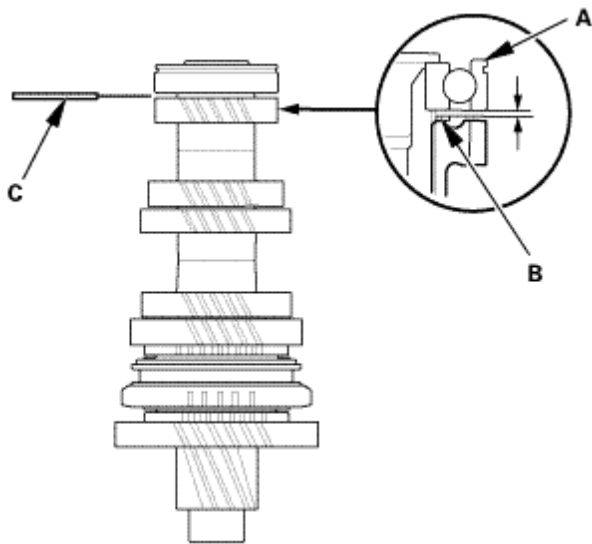

22. Measure the clearance between the ball bearing (A) and the 35 mm shim (B) with a feeler gauge (C).

**Standard: 0.04 – 0.10 mm (0.002 – 0.003 in)**

23. If the measured clearance in step 22 is not within the standard, select another suitable 35 mm shim from the table, then go to next step to replace the 35 mm shim and the ball bearing with new ones. If the measured clearance in step 22 is within the standard, go to next step to replace only the ball bearing with a new one.

**35 mm Shim**

Type	Thickness
A	0.87 mm (0.0343 in)
AA	0.91 mm (0.0358 in)
B	0.95 mm (0.0374 in)
AB	0.99 mm (0.0390 in)
C	1.03 mm (0.0406 in)
AC	1.07 mm (0.0421 in)
D	1.11 mm (0.0437 in)
AD	1.15 mm (0.0453 in)
E	1.19 mm (0.0469 in)
AE	1.23 mm (0.0484 in)
F	1.27 mm (0.0500 in)
AF	1.31 mm (0.0516 in)
G	1.35 mm (0.0531 in)
AG	1.39 mm (0.0547 in)
H	1.43 mm (0.0563 in)
AH	1.47 mm (0.0579 in)
J	1.51 mm (0.0594 in)
AJ	1.55 mm (0.0610 in)

Type	Thickness
K	1.59 mm (0.0626 in)
AK	1.63 mm (0.0642 in)
L	1.67 mm (0.0657 in)
AL	1.71 mm (0.0673 in)
M	1.75 mm (0.0689 in)
AM	1.79 mm (0.0705 in)
N	1.83 mm (0.0720 in)
AN	1.87 mm (0.0736 in)
P	1.91 mm (0.0752 in)
AP	1.95 mm (0.0768 in)
Q	1.99 mm (0.0783 in)

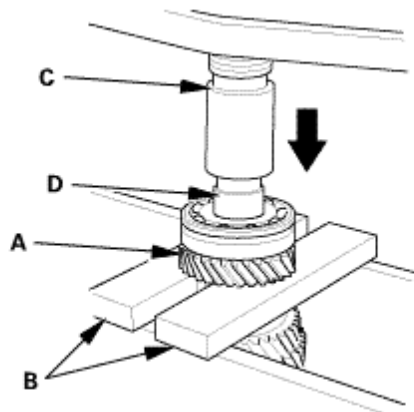

24. Support 6th gear (A) on steel blocks (B).

25. Use the press (C) and an attachment (D) to press the countershaft out of the ball bearing and 6th gear.

26. Remove the 35 mm shim.

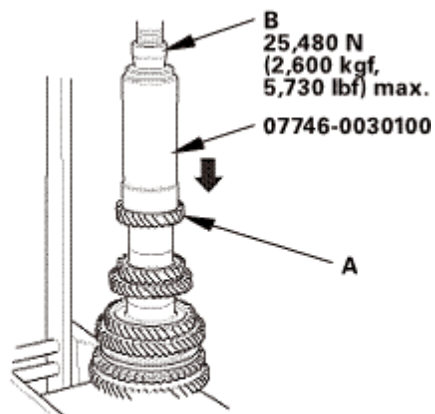

27. Press on 6th gear (A) using the 40 mm I.D. driver handle and the press (B).

NOTE: Do not exceed the maximum pressure.

28. Install the correct 35 mm shim (A).



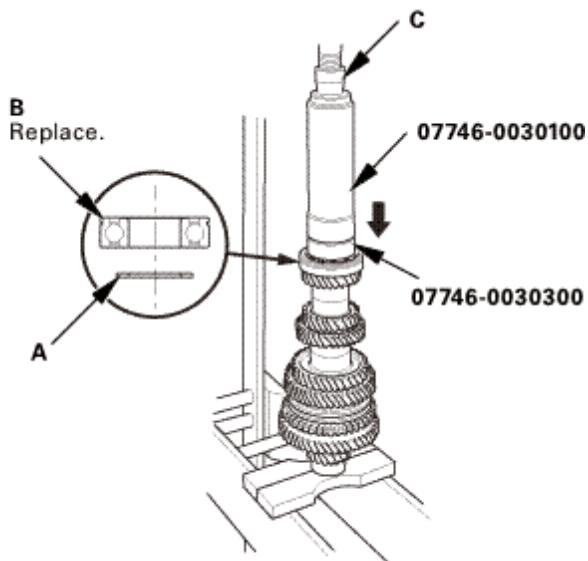

NOTE: If necessary, replace the 35 mm shim with the correct one selected in step 23.

29. Press on a new ball bearing (B) using the 40 mm I.D. driver handle, the 30 mm I.D. bearing driver attachment, and the press (C).

NOTE: Make sure the ball bearing is installed in the correct direction.

30. Recheck the clearance between the bearing and the 35 mm shim with a feeler gauge.

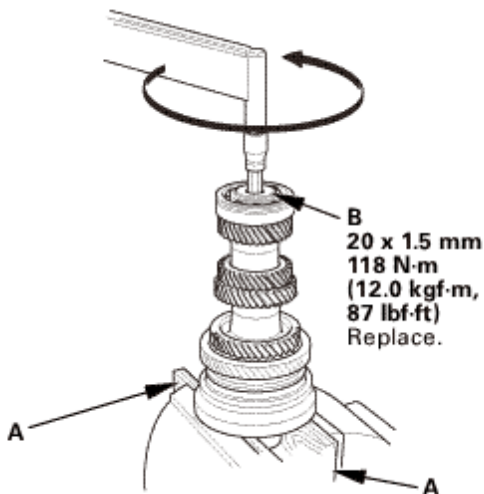

31. Securely clamp the countershaft assembly in a bench vise with wood blocks (A).

32. Tighten a new special bolt (B) (left-hand threads).

NOTE: Apply new MTF to the bolt threads and flange.

## 2. M/T Mainshaft and Countershaft and Shift Fork Assembly

1. Install the 28 mm spring washer (A).

NOTE: Be sure to install the spring washer in the direction shown.

2. Install the 28 mm washer (B).

3. Apply a thin layer of tape to the mainshaft splines (C) to protect the seal.

NOTE: Do not apply too much tape as it will damage the oil seal.

4. Install the mainshaft assembly (D) and the countershaft assembly (E) with the shift fork assembly (F), as an assembly.

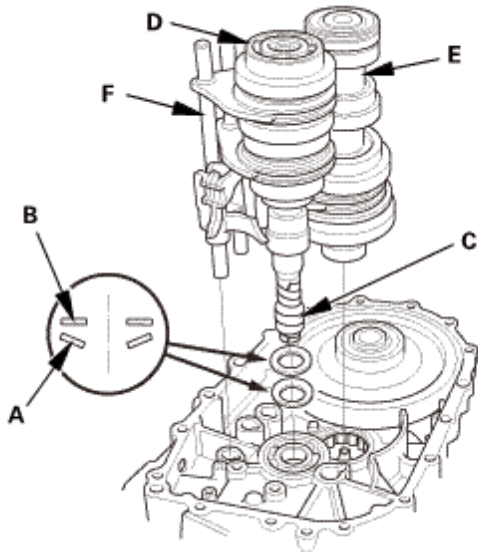

### 3. Reverse Idler Gear

1. Install the reverse idler gear (A) and reverse idler gear shaft (B) by aligning the mark (C) on the clutch housing with the reverse idler gear shaft hole (D).

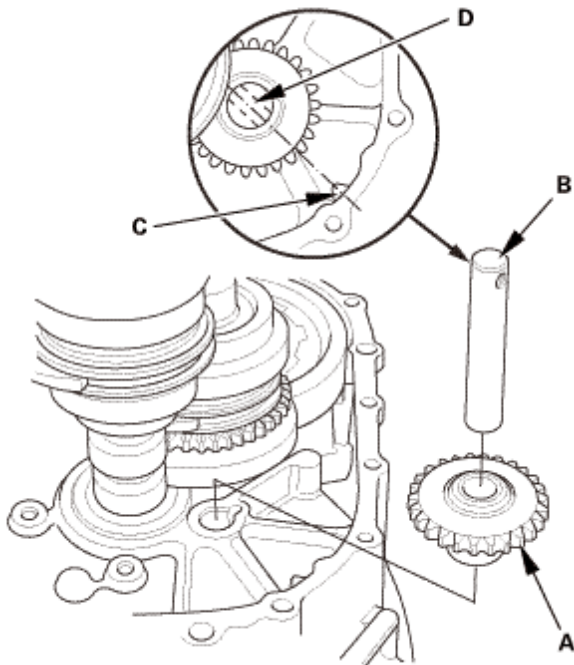

### 4. Baffle Plate

1. Install the baffle plate (A).

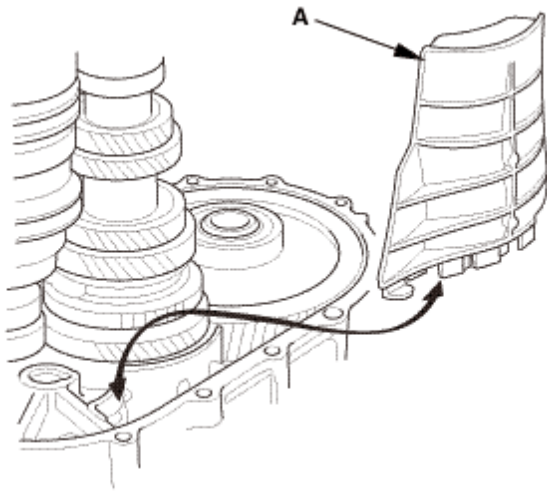

### 5. Reverse Shift Fork

1. Install the reverse shift fork (A).

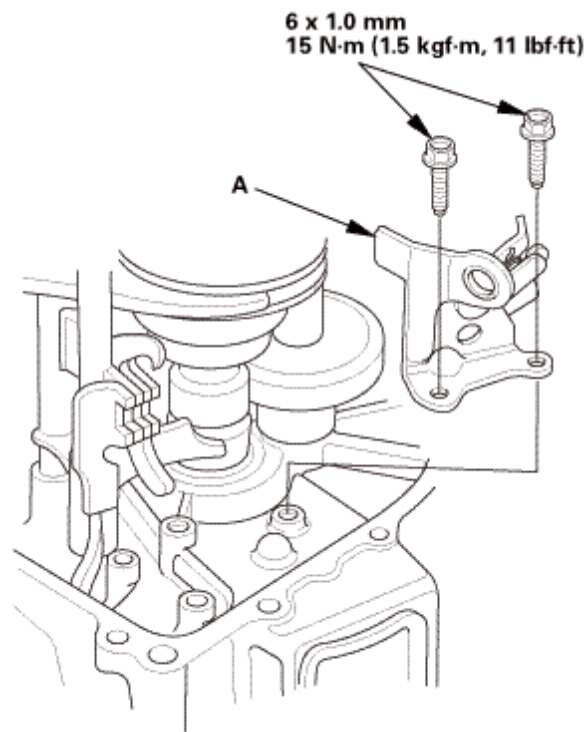

### 6. Transmission Housing

1. Clean any dirt or oil from the mating surface of the transmission housing and the clutch housing.
2. Apply liquid gasket, P/N 08717-0004, 08718-0001, 08718-0003, 08718-0004, or 08718-0009 evenly to the clutch housing mating surface of the transmission housing. Install the component within 5 minutes of applying the liquid gasket.

NOTE:

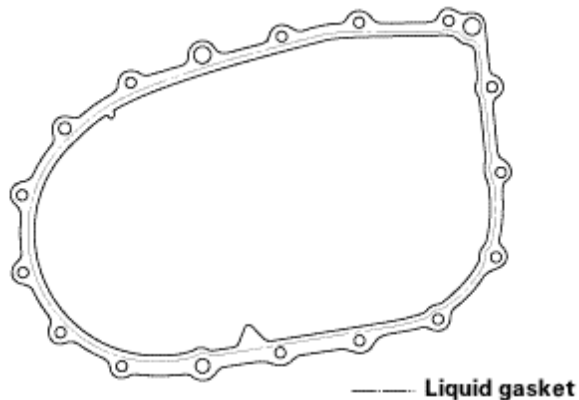

- If you apply liquid gasket P/N 08718-0012, the component must be installed within 4 minutes.
- If too much time has passed after applying the liquid gasket, remove the old liquid gasket and residue, then reapply new liquid gasket.

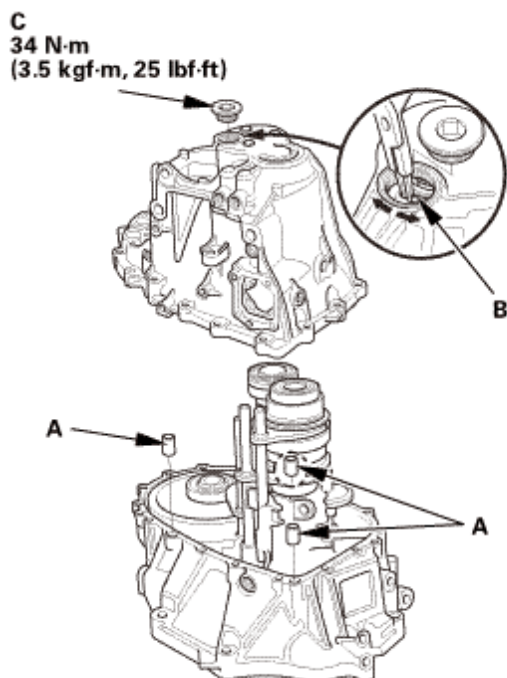

3. Install the 14 x 20 mm dowel pins (A).
4. Place the transmission housing on the clutch housing, making sure to line up the shafts.
5. While expanding the 72 mm snap ring (B) on the countershaft ball bearing using snap ring pliers, push the transmission housing down to start the countershaft ball bearing through the snap ring.
6. Release the pliers, and push down the housing until it bottoms out and the snap ring snaps in place in the countershaft ball bearing snap ring groove.

NOTE: Install the 32 mm sealing cap (C) after setting in the 72 mm snap ring.

7. Make sure the 72 mm snap ring (A) is securely seated in the groove of the countershaft bearing.

**Dimension ① as installed: 3.3 – 6.0 mm (0.130 – 0.236 in)**

8. Apply liquid gasket, P/N 08717-0004, 08718-0001, 08718-0003, 08718-0004, or 08718-0009 evenly to the threads of the 32 mm sealing cap. Install the component within 5 minutes of applying the liquid gasket.

NOTE:

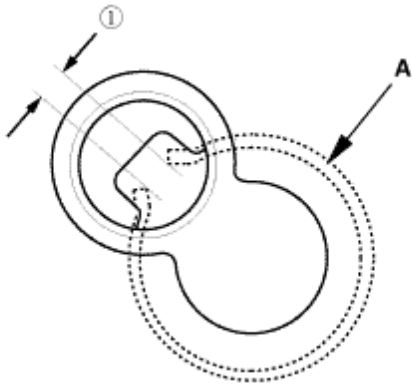

- If you apply liquid gasket P/N 08718-0012, the component must be installed within 4 minutes.
- If too much time has passed after applying the liquid gasket, remove the old liquid gasket and residue, then reapply new liquid gasket.

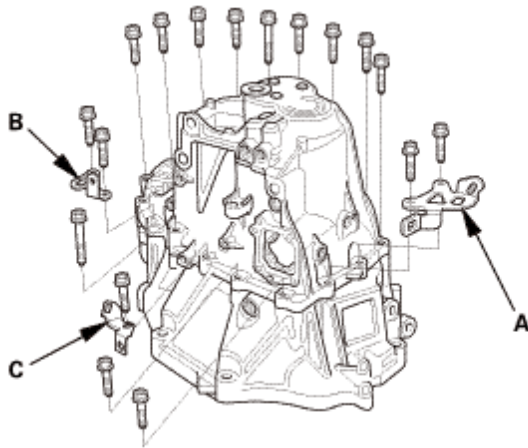

9. Install the 8 mm flange bolts finger-tight with transmission hanger A, transmission hanger B, and the harness bracket (C).

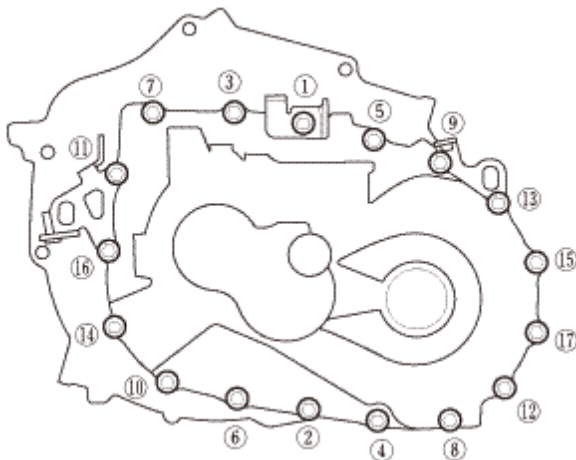

10. Tighten the 8 mm flange bolts in a crisscross pattern in several steps.

**Specified Torque:** 8 x 1.25 mm  
27 N·m (2.8 kgf·m, 20 lbf·ft)

11. Install the 10 mm flange bolt (A) with new sealing washer (B).

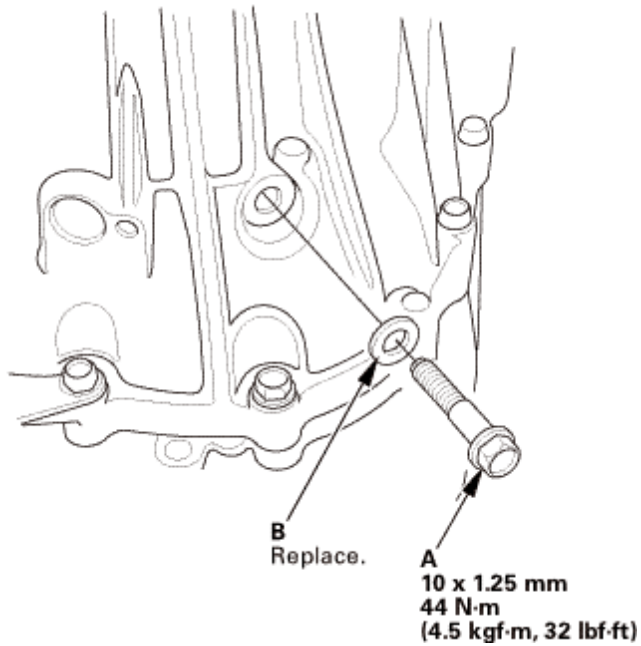

12. Install the steel balls, the detent ball springs, and the detent bolts (A) with new 12 mm sealing washers (B).

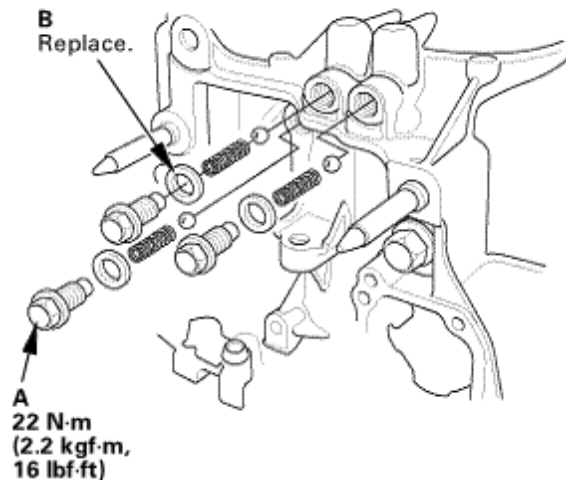

#### 7. Output Shaft (Countershaft) Speed Sensor

1. Apply MTF to a new O-ring (A).
2. Install the output shaft (countershaft) speed sensor (B) with the O-ring and the plain washer (C).

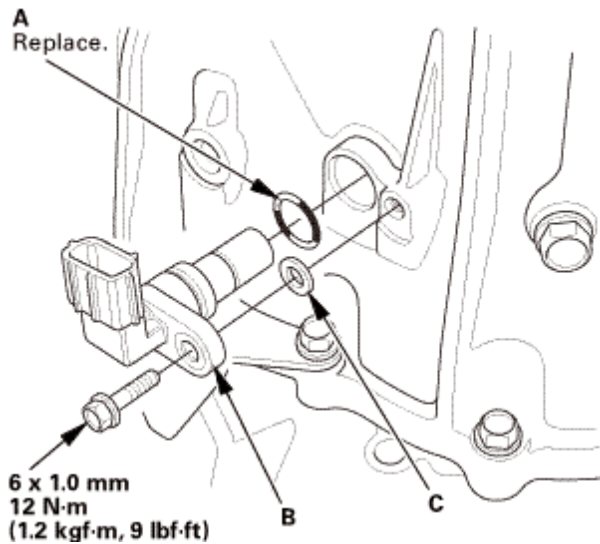

### 8. Back-Up Light Switch

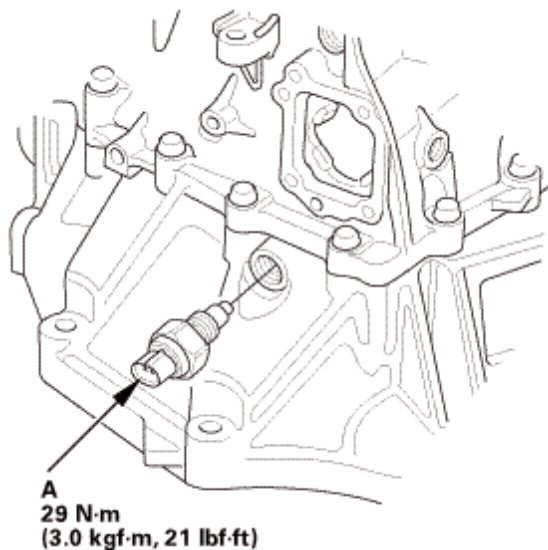

1. Apply liquid gasket (P/N 08717-0004, 08718-0001, 08718-0012, 08718-0003, 08718-0004, or 08718-0009) to the threads of the back-up light switch (A).
2. Install the back-up light switch.

### 9. M/T Change Lever Assembly

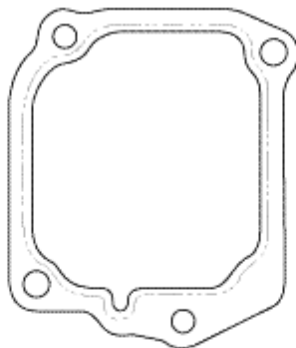

----- Liquid gasket

1. Clean any dirt or oil from the mating surface of the change lever assembly and the transmission housing.
2. Apply liquid gasket, P/N 08717-0004, 08718-0001, 08718-0003, 08718-0004, or 08718-0009 evenly to the transmission housing mating surface of the change lever assembly. Install the component within 5 minutes of applying the liquid gasket.

**NOTE:**

- If you apply liquid gasket P/N 08718-0012, the component must be installed within 4 minutes.
-

If too much time has passed after applying the liquid gasket, remove the old liquid gasket and residue, then reapply new liquid gasket.

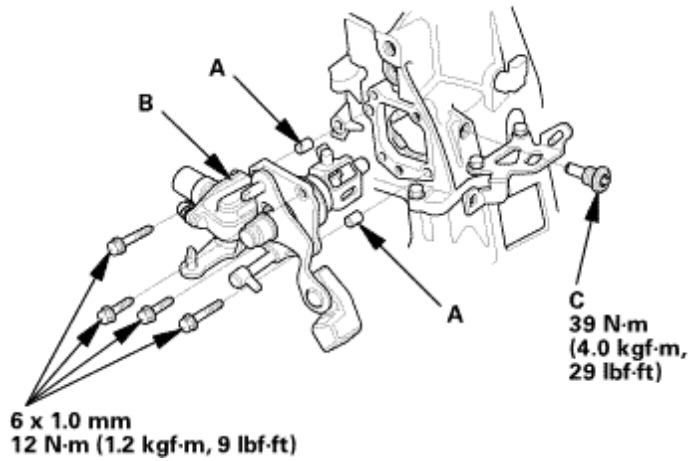

3. Install the 8 x 14 mm dowel pins (A).
4. Install the change lever assembly (B).
5. Apply liquid gasket (P/N 08717-0004, 08718-0001, 08718-0012, 08718-0003, 08718-0004, or 08718-0009) to the threads of the interlock bolt (C).
6. Install the interlock bolt.