



Applies To: **ALL**

December 19, 2000

## Terminal Replacement Instructions

(Replaces 95-023, dated May 1, 1995)

These terminal replacement instructions apply to these kits and tools:

- Terminal Pin Kit A: T/N 07JAZ-003000B
- Terminal Pin Kit B: T/N 07QAZ-003020B
- Terminal Inspection Feeler Tool Set: T/N 07XAJ-001000A

This bulletin covers these topics:

- How to Replace Connector Terminals
- How to Install New Terminals
- How to Install Pigtail Terminals
- Pigtail Terminal Selection Chart
- Checking for Poor Fit of Terminals

### WARRANTY CLAIM INFORMATION

None; this bulletin is for information only.

### PARTS INFORMATION

Terminal Inspection Feeler Tool Set:  
T/N 07XAJ-001000A

Terminal Pin Kit A: T/N 07JAZ-003000B, which contains Pin Tool Set T/N 07JAZ-002000A, Crimper T/N 07JAZ-001020A, and various terminals.

Terminal Pin Kit B: T/N 07QAZ-003020B, which contains Crimper Tool Set T/N 07NGZ-001010A (used on splice connectors only), Heat Gun T/N 07NGZ-001020A, various terminals, and splice connectors.

The following kit has been shipped to dealerships. This kit is to be added to Terminal Pin Kit B, T/N 07QAZ-003020B:

Terminal Pin Update Kit, T/N 07XAZ-002000A which includes 25 each of the following terminals:

P/N 07JAZ-001320A

P/N 07JAZ-001330A

P/N 07JAZ-001340A

P/N 07JAZ-001350A

P/N 07JAZ-001360A

P/N 07JAZ-001370A

P/N 07JAZ-001380A

P/N 07JAZ-001400A

P/N 07JAZ-001410A

1 pc inner and outer label for Terminal Pin Kit B: T/N 07QAZ-003020B.

Replacement terminals, wire seals, and splice connectors are listed on the inside lid of each terminal pin kit.

Additional information on replacement connectors, terminals, and pigtails is listed in the Honda Electrical Connector Catalog (P/N 13CNNA-3).

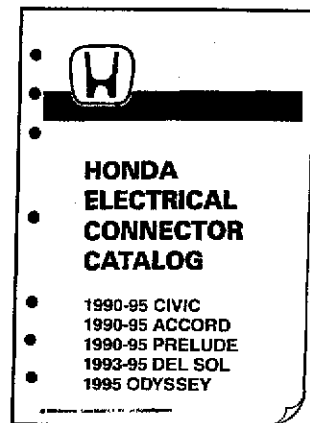

058659

## HOW TO REPLACE CONNECTOR TERMINALS

The terminal repair kits provide necessary tools and materials (terminals, wire seals, and splice connectors) to repair many damaged or faulty connector terminals. However, not all terminals for all connectors are available. Refer to the labels on the lids of the repair kits for replacement terminal availability.

### IMPORTANT SAFETY INFORMATION:

On some models, the SRS wires are in a separate harness. If the SRS harness is damaged, replace the harness; do not repair it. On other models, wire harnesses include yellow SRS wires. If any SRS wire is damaged, replace the entire harness; do not repair it.

Before you begin, inspect the wire you are about to repair for damage and length. Make sure the wire will be long enough to make a terminal repair without stretching it when you reinstall the terminal in the connector. If the wire is too short, or if access to the connector is too restricted to make a terminal repair, you may need to install a pigtail terminal (a short length of wire with a factory-cripped terminal on it). Refer to HOW TO INSTALL PIGTAIL TERMINALS.

### Removing the Terminal

Use the tools from Pin Tool Set T/N 07JAZ-002000A.

First, check the connector that you are about to repair.

- If it has a secondary terminal lock, go to Connectors With a Secondary Lock. A secondary lock, found on most connectors on some models, is an additional locking device on the connector housing as a backup for the primary lock on the terminal.
- If the connector does not have a secondary lock, go to Connectors Without a Secondary Lock.

### Connectors With a Secondary Lock

All examples are shown with the connector lock facing up. The illustrations are examples of the secondary terminal locks; however, the connector you are repairing may vary in size. Identify the connector by the type of secondary lock, not by the number of terminal cavities.

#### EXAMPLE A:

1. Release the secondary lock.

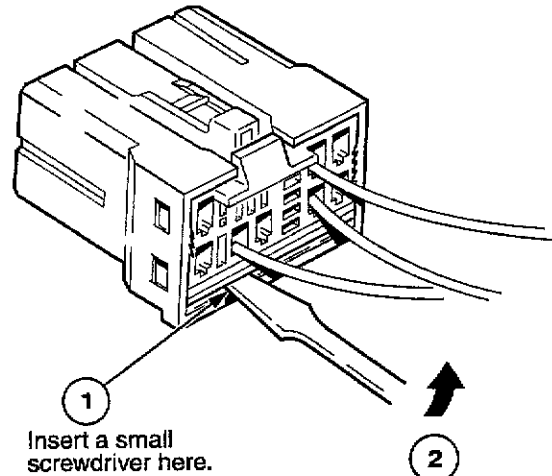

1  
Insert a small screwdriver here.

2  
Lift up on the screwdriver and the lock will "snap" upward.

2. Remove the terminal.

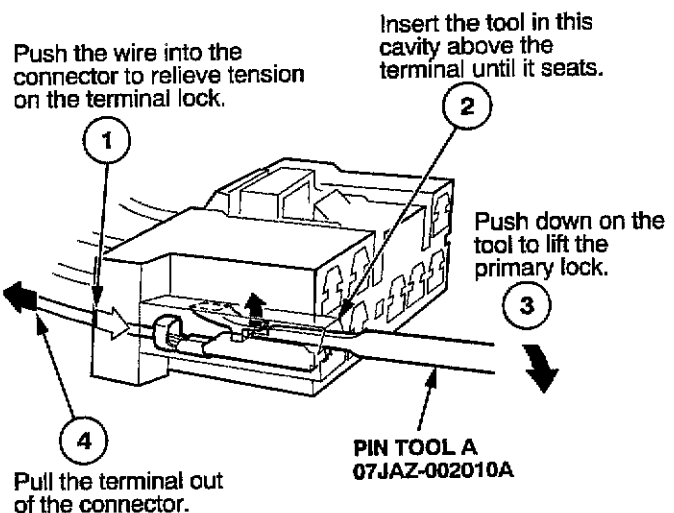

1  
Push the wire into the connector to relieve tension on the terminal lock.

2  
Insert the tool in this cavity above the terminal until it seats.

3  
Push down on the tool to lift the primary lock.

4  
Pull the terminal out of the connector.

PIN TOOL A  
07JAZ-002010A

3. Go to HOW TO INSTALL NEW TERMINALS.

**EXAMPLE B:**

1. Remove the secondary lock from the male terminal half.

- Male Terminal Half

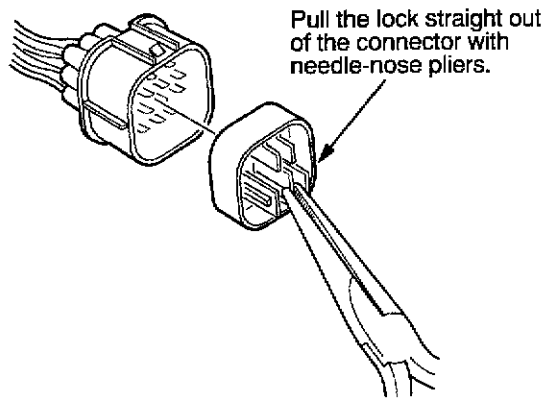

2. Remove the secondary lock from the female terminal half.

- Female Terminal Half

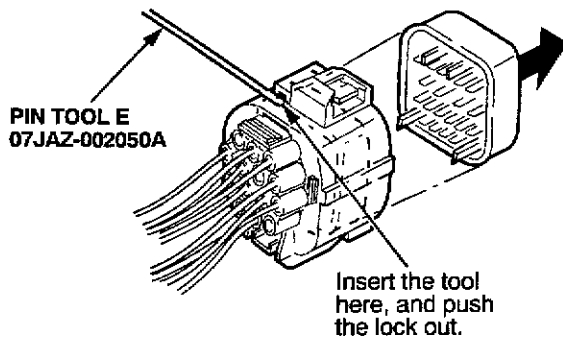

3. Remove the terminal (same procedure for male and female).

Push the wire into the connector to relieve the tension on the primary lock.

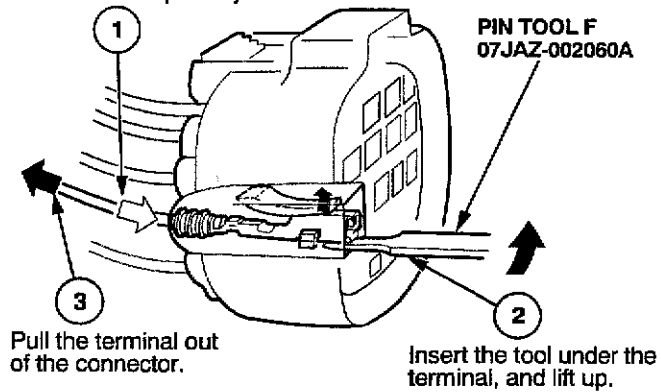

4. Go to HOW TO INSTALL NEW TERMINALS.

**EXAMPLE C:**

1. Remove the secondary lock.

Carefully pry the secondary lock out of the connector.

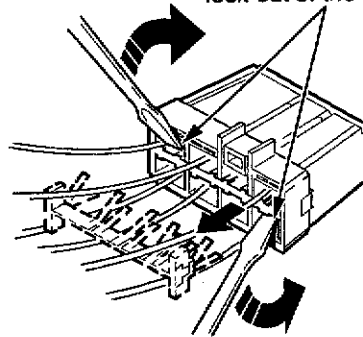

2. Remove the terminal from the female half.

- Female Terminal Half

Push the wire into the connector to relieve the tension on the primary lock.

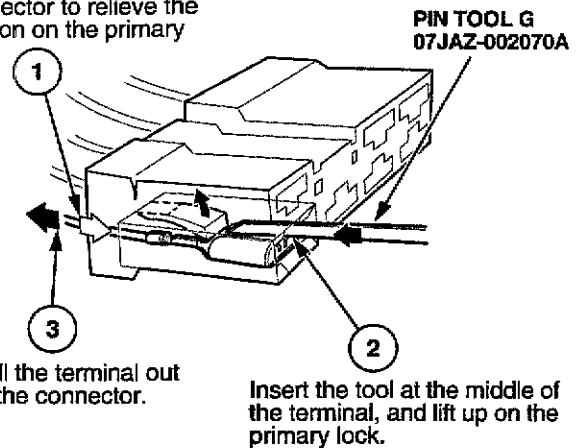

3. Remove the terminal from the male half.

- Male Terminal Half

Push the wire into the connector to relieve the tension on the primary lock.

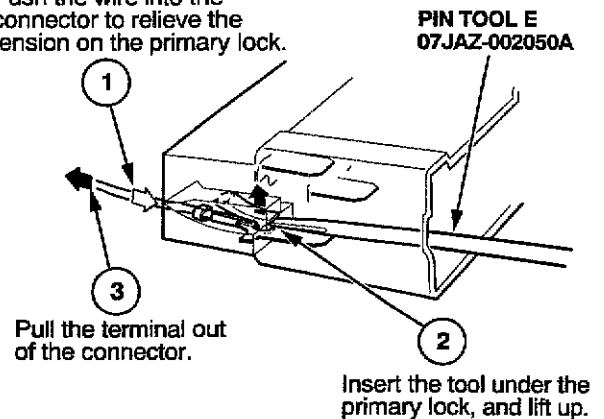

4. Go to HOW TO INSTALL NEW TERMINALS.

**EXAMPLE D:**

1. Remove the secondary locks.

Pry out on the tabs on both sides.

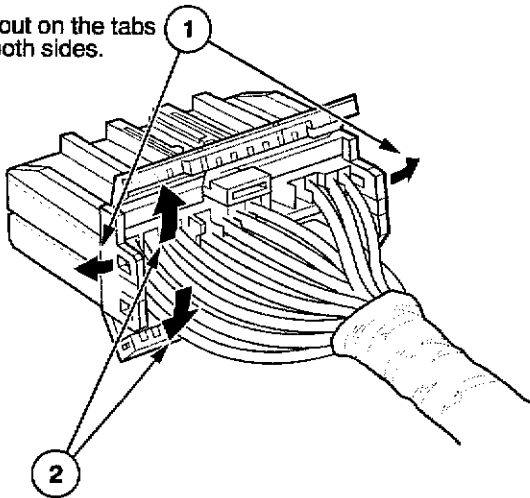

Roll the upper and lower locks in the direction of the arrows.

2. Remove the terminal (same procedure for male and female).

Push the wire into the connector to relieve the tension on the primary lock.

Insert the tool into the upper half of the terminal cavity.

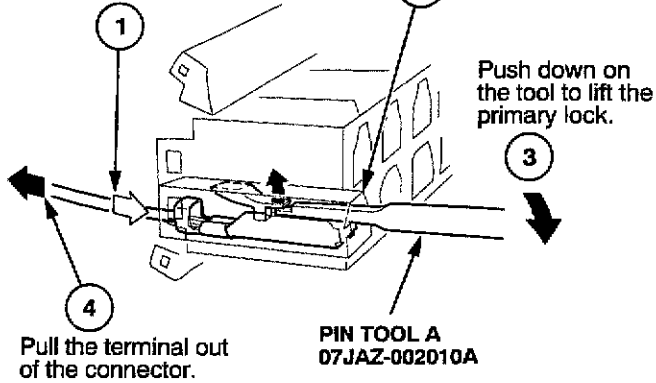

Push down on the tool to lift the primary lock.

Pull the terminal out of the connector.

**PIN TOOL A**  
07JAZ-002010A

3. Go to HOW TO INSTALL NEW TERMINALS.

**EXAMPLE E:**

1. Remove the secondary locks.

Gently pry up on the back of the secondary terminal lock.

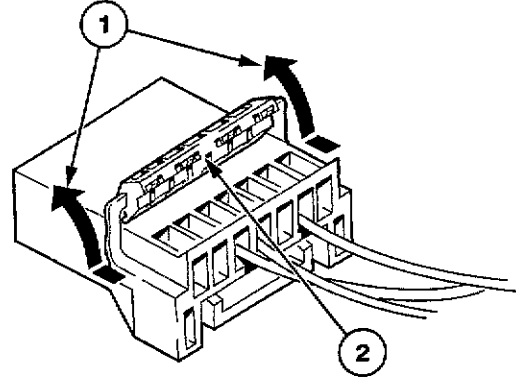

Roll the secondary lock up so the lugs of the lock are free of the connector.

2. Remove the terminal (same procedure for male and female).

Push the wire into the connector to relieve the tension on the primary lock.

Insert the tool into the larger hole in the face of the connector.

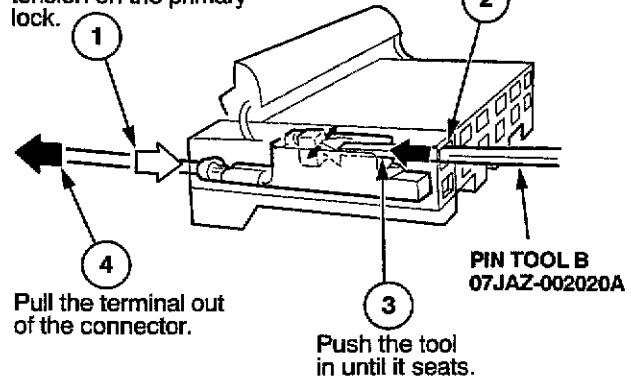

**PIN TOOL B**  
07JAZ-002020A

Pull the terminal out of the connector.

Push the tool in until it seats.

3. Go to HOW TO INSTALL NEW TERMINALS.

**EXAMPLE F:**

1. Remove the secondary locks.

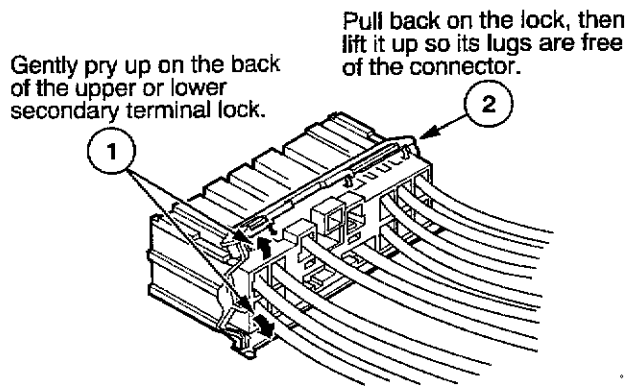

2. Remove the terminal from the female half.

- Female Terminal Half

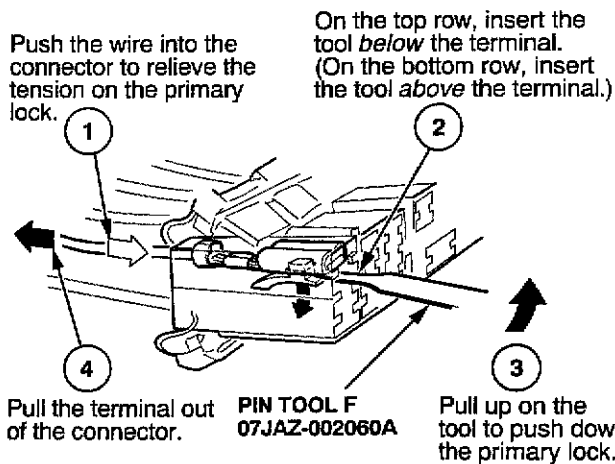

3. Remove the terminal from the male half.

- Male Terminal Half

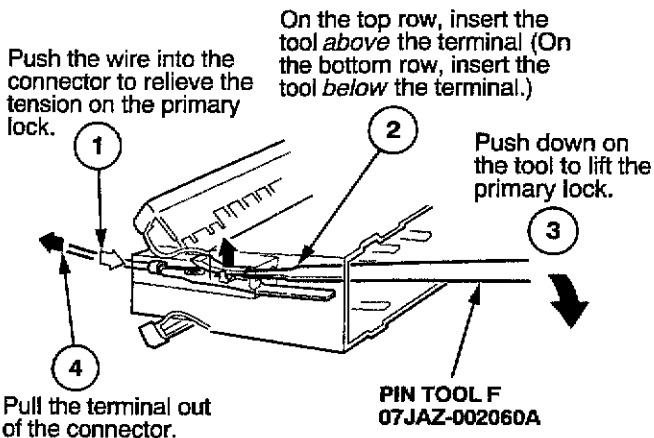

4. Go to HOW TO INSTALL NEW TERMINALS.

**Connectors Without a Secondary Lock**

All examples are shown with the connector lock facing up. The illustrations are examples of connector terminals without a secondary lock; however, the connector you are repairing may vary in size and shape.

**EXAMPLE A:**

1. Remove the terminal.

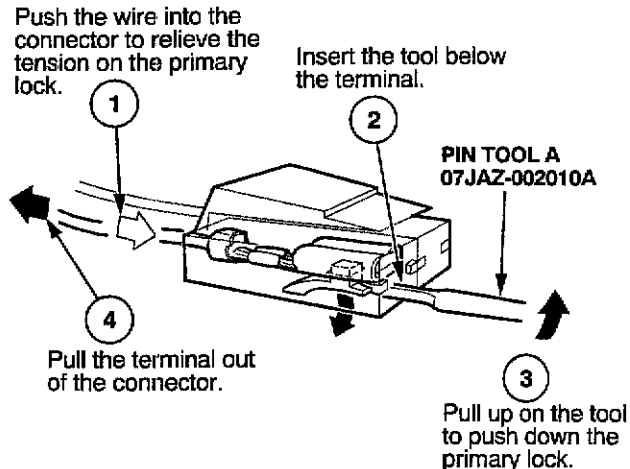

2. Go to HOW TO INSTALL NEW TERMINALS.

**EXAMPLE B:**

1. Remove the terminal.

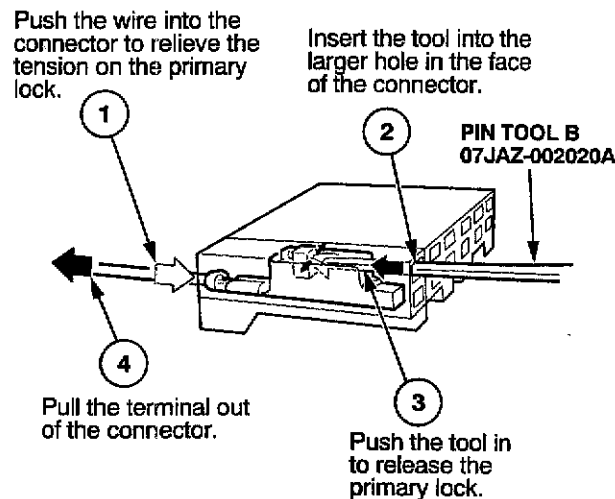

2. Go to HOW TO INSTALL NEW TERMINALS.

**EXAMPLE C:**

1. Remove the terminal.

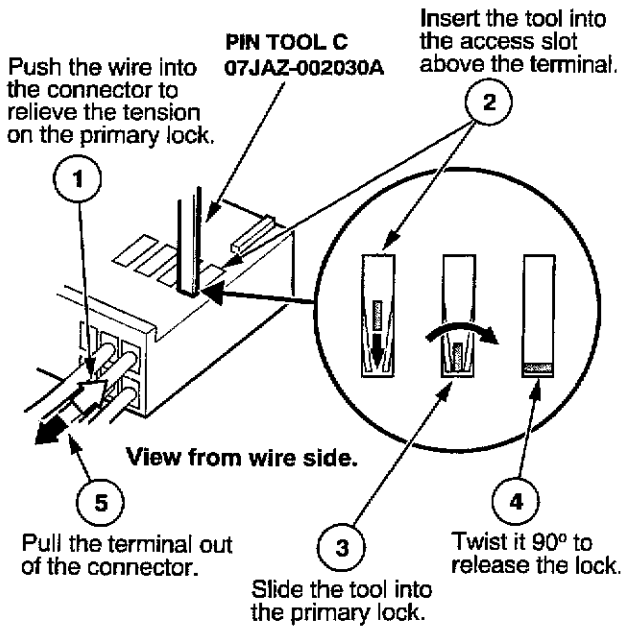

2. Go to HOW TO INSTALL NEW TERMINALS.

**EXAMPLE D:**

1. Remove the terminal.

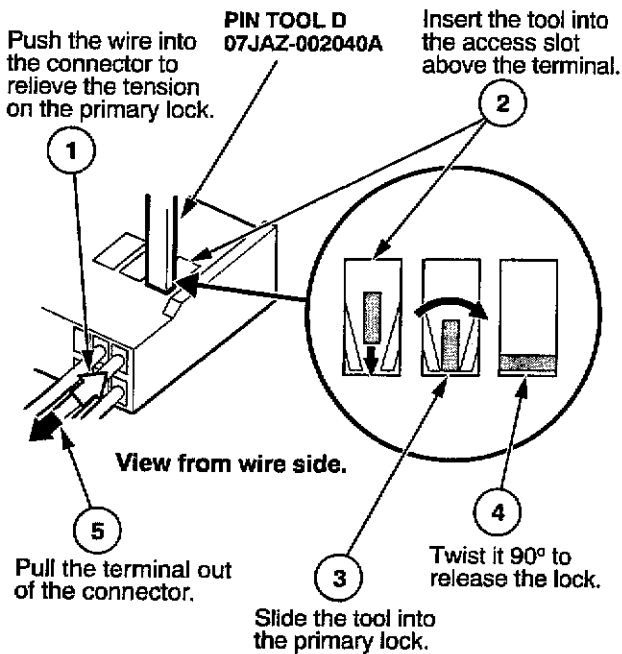

2. Go to HOW TO INSTALL NEW TERMINALS.

**EXAMPLE E:**

1. Remove the terminal.

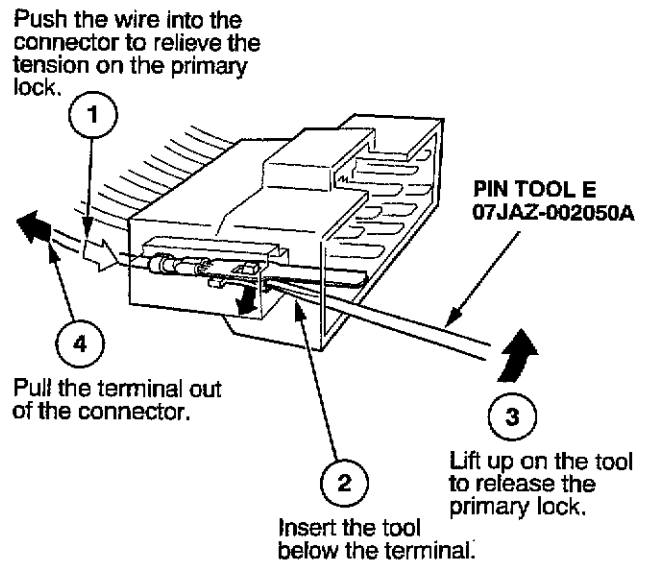

2. Go to HOW TO INSTALL NEW TERMINALS.

**EXAMPLE F:**

1. Remove the terminal.

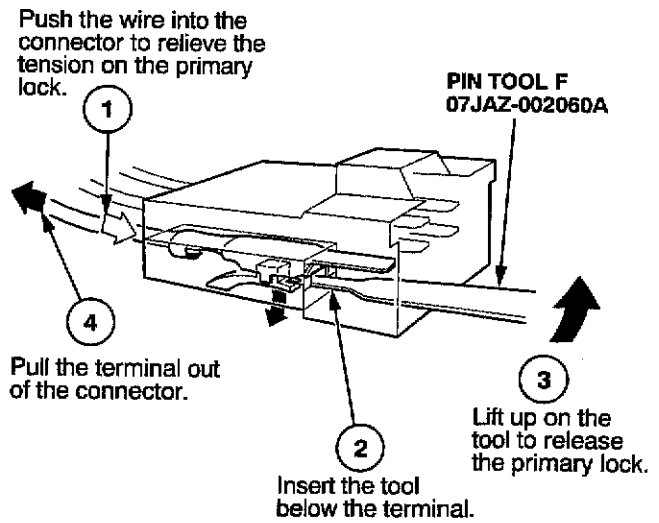

2. Go to HOW TO INSTALL NEW TERMINALS.

### EXAMPLE G:

1. Remove the terminal.

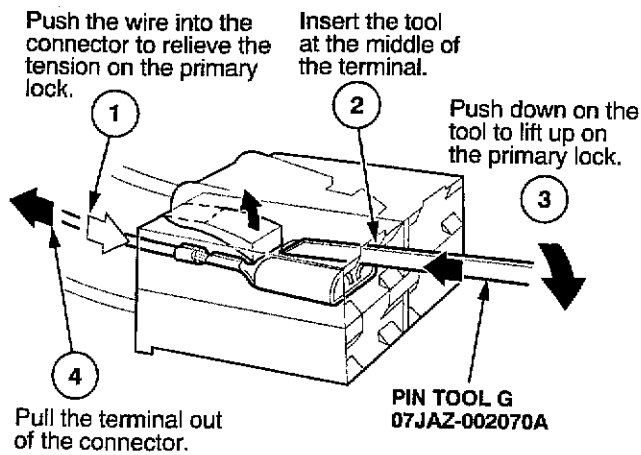

2. Go to HOW TO INSTALL NEW TERMINALS.

### HOW TO INSTALL NEW TERMINALS

1. Carefully match the old terminal with a new one from the terminal repair kit. Choose the correct replacement terminal based on the wire size range the terminal will accommodate.

NOTE: If the replacement terminal quantities are low, reorder them by using the terminal part number listed on the inside lid of the terminal repair kit. Replacement terminals are available through your parts department using normal parts ordering procedures.

2. Depending on the size of the wire you are repairing, use the proper size slot in the crimping tool.

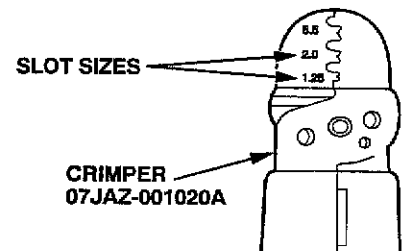

3. Strip the insulation off the end of the wire so the wire fits in the new terminal as shown. (If the wire has a wire seal, replace it with a new one from the kit.)

NOTE: After stripping the end of the wire, make sure you did not cut any wire strands. If you did, cut the wire off even with the insulation, and strip it again.

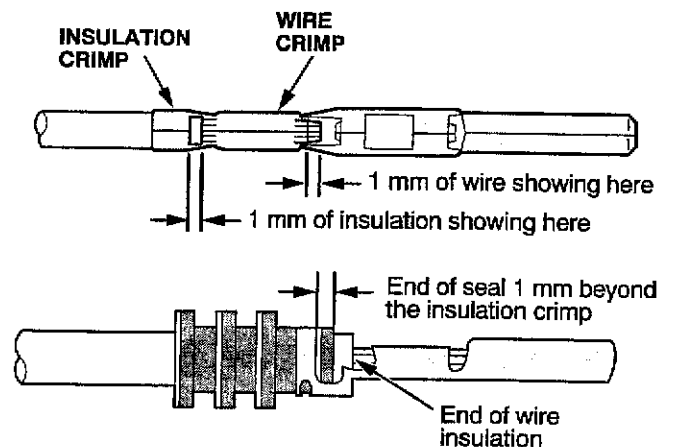

- Position the terminal in the crimping tool slot with the solid portion of the terminal toward the anvil and the open section toward the former.

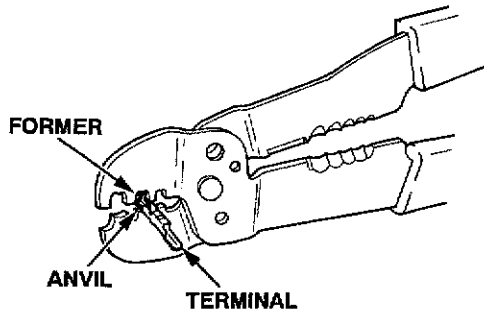

- Insert the wire in the terminal to the position shown in step 3.
- Squeeze the tool with both hands until the stops make contact.

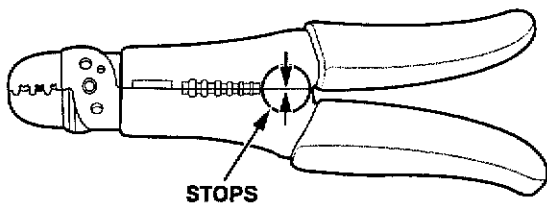

- Crimp the insulation crimp.

- If you do not have a wire seal, then use the next larger size crimp slot. Position the crimping tool over the insulation crimp section of the terminal, then squeeze the tool with both hands until the stops make contact.
- If you have a wire seal, position the insulation crimp in the 5.5 crimping slot, then carefully squeeze the crimp closed until its ends are touching and making a full-circle shape.

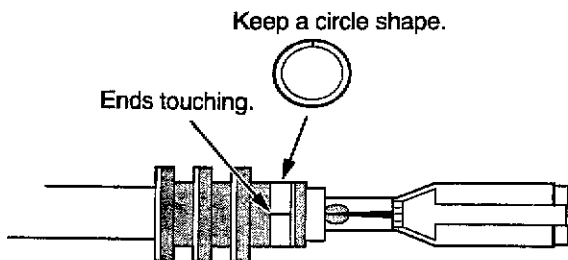

- Inspect the quality of the wire crimp. If it has any of the following NO GOOD crimps, cut it off and start over.

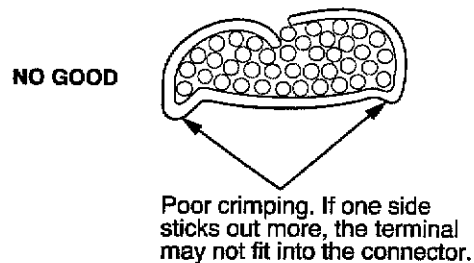
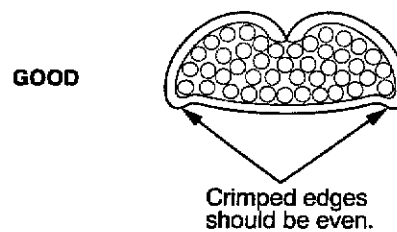
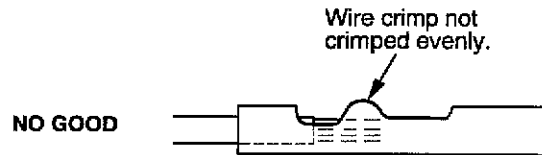
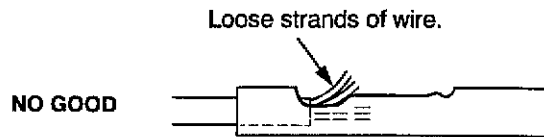
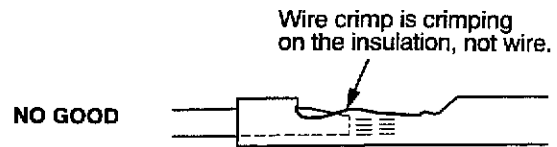
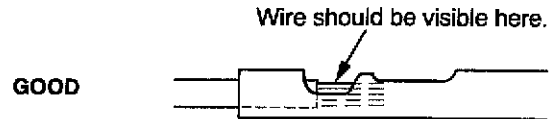

- Insert the terminal into the connector. Make sure the wire seals are pushed all the way into the connector. Lightly pull on the wires to make sure the terminal is locked into place.
- Close or insert the secondary terminal lock, if applicable, and reconnect the connector.

#### HOW TO INSTALL PIGTAIL TERMINALS

Pigtail terminals (short pieces of wire with a factory crimped terminal) are used when the wire is too short or when access to the connector is too restricted to make a terminal repair. Refer to the selection chart on page 11.



NOTE: To replace just a connector terminal, go to *How to Replace Connector Terminals*.

**IMPORTANT SAFETY INFORMATION:**

On some models, the SRS wires are in a separate harness. If the SRS harness is damaged, replace the harness; do not repair it. On other models, wire harnesses include yellow SRS wires. If any SRS wire is damaged, replace the entire harness; do not repair it.

1. Remove the damaged or faulty terminal from the connector. Use the proper removal tool from Pin Tool Set T/N 07JAZ-002000A.
2. Cut off the wire about an inch back from where it connects to the damaged or faulty terminal, then strip about half of the insulation off that piece. This will be used to size the wire end of the replacement pigtail terminal.

NOTE: If you are not sure of the wire size, start with a large enough hole on the stripper that will not nick or cut off any strands of wires.

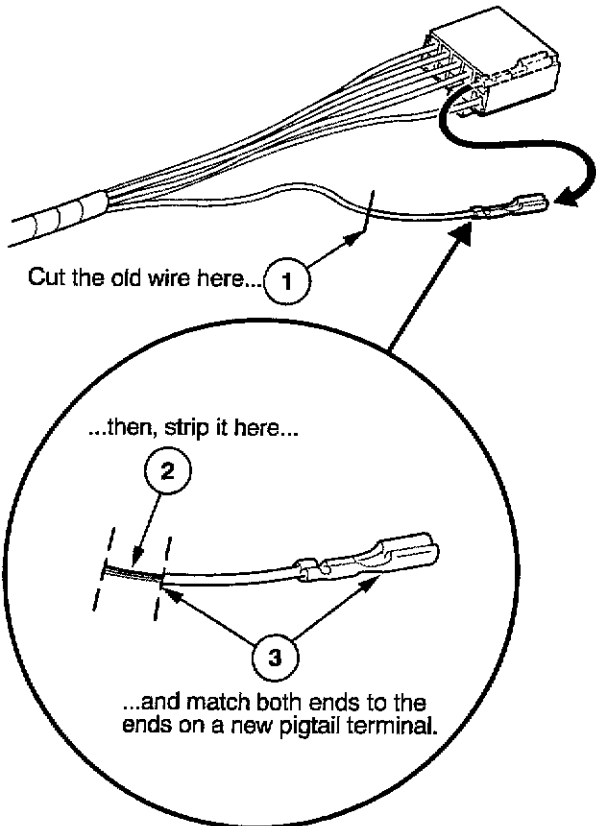

3. Select a pigtail terminal that matches the original wire at both ends (same kind of terminal and same diameter bare wire).
4. Select the smallest splice connector (yellow, pink, or blue) that will fit onto the stripped end of the original wire.

5. Insert the pigtail terminal into the connector cavity; push it in until it locks in place.

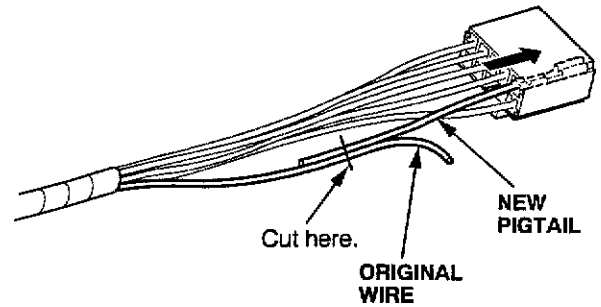

6. Lay the pigtail and the original wire side-by-side, and cut off both ends at once. If you are making more than one splice, do not cut each pigtail at the same location; the resulting "lump" of splice connectors would interfere with rewiring the harness. Instead, cut the first pigtail close enough to the terminal so you will have room to make each remaining cut about 20 mm (3/4 inch) farther down on the next pigtail.
7. If you are using a yellow splice connector, strip about 6 mm (1/4 inch) of insulation off the ends of both wires. If you are using a pink or blue splice connector, strip off about 8 mm (5/16 inch) of insulation.

NOTE: If you nick or cut off any strands of wire, try again with the next larger size hole on the stripper.

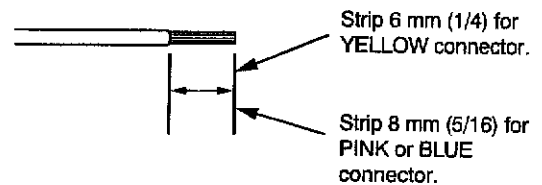

- Put the splice connector in the proper size slot in the Crimper Tool, T/N 07NGZ-001010A, slide it to one end (where the flare begins), and close the crimper handles far enough to hold it in place. To release the ratchet mechanism at any point after the first click, squeeze the handles slightly and push the release lever, then let the handles open.

Do not loosen or remove this screw; it has been set to release the ratchet at proper crimping pressure.

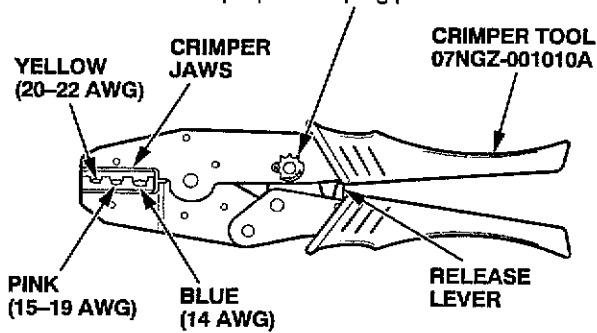

- Insert one of the bare wires into the splice connector end that is in the crimper jaws. Push the wire all the way into the splice connector, and squeeze the crimper handles. Keep squeezing until the jaws touch, and hold it at that position until the ratchet clicks again.

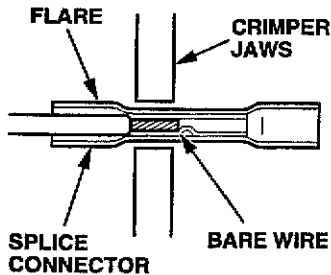

- Crimp the other wire in the same way into the other end of the splice connector.
- After crimping, gently pull on the wires in the opposite directions to make sure they are secure in the connector.

- Separate the other wires in the harness from the repaired wire(s), and shield them with nonflammable material.

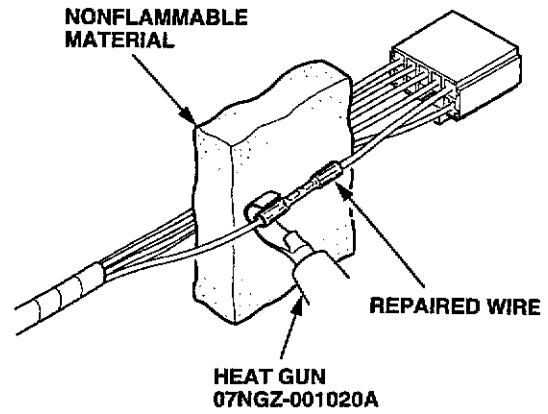

- Plug in the heat gun, and turn it on. Start at the middle of the splice connector, and move the gun toward the ends as the tube shrinks. Apply heat evenly by rotating the curved heat spreader around the splice connector. Shrinking is complete when a small amount of sealant appears at each end of the tube.

NOTE: Be careful when working with the high heat produced by the heat gun.

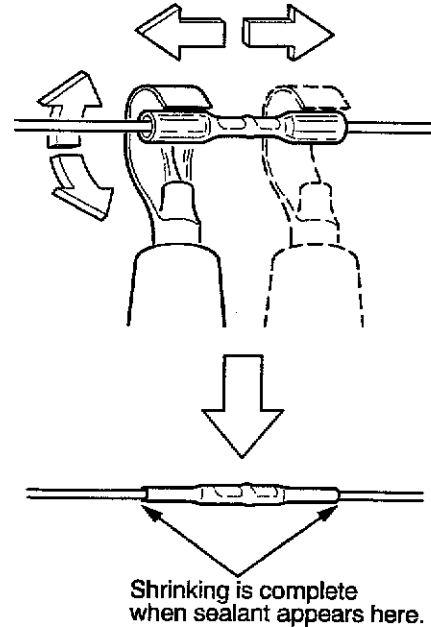

## PIGTAIL TERMINAL SELECTION CHART

Select the proper size pigtail terminal by matching the replacement terminal part number and the wire size being repaired to the corresponding pigtail terminal part number. Then use the color (size) splice connector listed. In some instances you may also have to match the wire seal style to select the proper pigtail terminal. Pigtail terminals are available through your parts department, in quantities of 10, using normal parts ordering procedures.

### Wire Seal Type

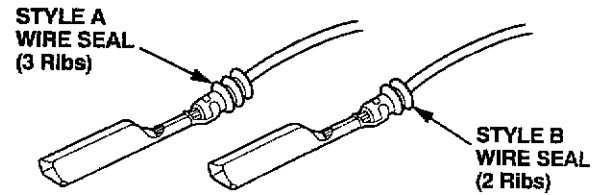

Replacement Terminal P/N	Wire Size Being Repaired	Pigtail Terminal P/N	Splice Connector Color	Wire Seal Style
07JAZ-001040A	20 AWG	04320-SP0-A00	Yellow	
	16 AWG	04320-SP0-B00	Pink	
07JAZ-001090A	20 AWG	04320-SP0-C00	Yellow	A
	16 AWG	04320-SP0-D00	Pink	A
	20 AWG	04320-SP0-E00	Yellow	B
	16 AWG	04320-SP0-F00	Pink	B
07JAZ-001030A	20 AWG	04320-SP0-G00	Yellow	
07JAZ-001080A	20 AWG	04320-SP0-J00	Yellow	
	16 AWG	04320-SP0-M00	Pink	
07JAZ-001260A	20 AWG	04320-SP0-A10	Yellow	
	16 AWG	04320-SP0-N00	Pink	
07JAZ-001220A	16 AWG	04320-SP0-P00	Pink	
07JAZ-001280A	16 AWG	04320-SP0-P00	Pink	
07JAZ-001230A	20 AWG	04320-SP0-S00	Yellow	
	16 AWG	04320-SP0-T00	Pink	
	14 AWG	04320-SP0-U00	Blue	
07JAZ-001240A	20 AWG	04320-SP0-V00	Yellow	
	16 AWG	04320-SP0-W00	Pink	
07JAZ-001290A	20 AWG	04320-SP0-Y10	Yellow	
①	20 AWG	04320-SP0-B10	Yellow	
①	20 AWG	04320-SP0-F10	Yellow	
①	20 AWG	04320-SP0-K10	Yellow	
①	20 AWG	04320-SP0-N10	Yellow	
①	20 AWG	04320-SP0-R10	Yellow	

① Replacement terminals are not available. Instead, refer to the Honda Electrical Connector Catalog for proper pigtail terminal applications.

## CHECKING FOR POOR FIT OF TERMINALS

Loose terminal fit can cause a number of intermittent problems in electrical circuits. By using the Terminal Inspection Feeler Tool Set T/N 07XAJ-001000A, you can inspect the terminal fit between the two matching connectors without removing the terminals from the connector body.

1. Find the terminal tool that best matches the male terminal in the mating connector.
2. Insert the terminal tool into the female terminal, and then remove the terminal tool.

**NOTE:** Make sure you do not select a terminal tool that is larger than the mating male terminal because it would spread the female terminal and cause a loose fit.

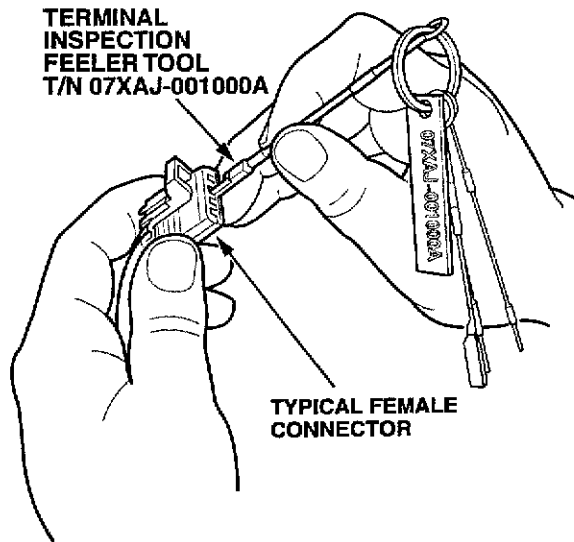

3. Compare the drag to the other terminals in the connector. If the drag is less, replace the terminal with a replacement terminal from the appropriate terminal repair kit.