



## Warranty Extension: MIL Comes On With DTCs P0301 Through P0304

### BACKGROUND

American Honda is announcing a powertrain warranty extension as a result of a settlement of a class captioned, *Soto et al. v. American Honda Motor Co., Inc.*, Case No. 3:12-cv-1377-SI (N.D. Cal.).

The piston rings on certain cylinders may rotate and align which can lead to spark plug fouling. This can set DTCs P0301 through P0304 and cause the MIL to come on.

American Honda is extending the powertrain warranty to cover repairs related to engine misfire (that triggers DTCs P0301 through P0304) to 8 years with unlimited mileage from the original date of purchase and has settled a class action based on this remedial measure.

This warranty extension does not apply to any vehicle that has ever been declared a total loss or sold for salvage by a financial institution or insurer, or has a branded or similar title under any state's law.

### CUSTOMER NOTIFICATION

Owners of affected vehicles will be sent a class action settlement notice regarding this warranty extension starting in October 2013.

Before doing work on a vehicle, verify its eligibility by doing an iN VIN status inquiry.

Refer customers seeking information about settlement benefits to [www.enginemisfiresettlement.com](http://www.enginemisfiresettlement.com), or instruct them to call **888-888-3082**.

### CORRECTIVE ACTION

Inspect the vehicle and, if necessary, clean the pistons, and replace the piston rings in the affected cylinders.

### PARTS INFORMATION

NOTE: Do the DIAGNOSIS first to determine which cylinders you will need to repair.

#### Required Parts

Part Name	Part Number	Cyl 1-3	Cyl 1-4
Cyl. Gasket (Fr)	12251-R70-A01		1
Cyl. Gasket (Rr)	12261-R70-A01	1	1
Drain Washer 14 mm	94109-14000	1	1
EGR Pipe Gasket A	18716-R70-A01	1	1
EGR Pipe Gasket B	18719-R70-A01	1	1
Ex. Chamber Gasket	18115-R70-A01	1	2
Ex. Pipe Gasket	18212-SA7-003	2	2
Head Gasket Set	12030-R70-A00		1
Head Gasket Rr.	12050-R70-A00	1	1
In. Manifold Gasket	17146-R70-A01	1	1
In. Manifold Gasket	17105-RCJ-A01	1	1
Oil Filter	15400-PLM-A02	1	1
O-ring (7.47 mm x 3.6 mm)	91301-PLC-000	2	2
O-ring (31.2mm x4.1 mm)	91314-PH7-003	2	2
Piston Ring Set	13011-5G0-A02	3	4
Pre-chamber Gasket	18393-SDB-A00	1	1
Self-locking Nut (8 mm)	90212-RCA-A01	4	8
Self-locking Nut (10 mm)	90212-SA5-003	9	9
Spark Plug	12290-R70-A01	4	4
Strainer O-ring	15221-RYE-A01	1	1
Timing Belt Bolt	14551-RCA-A01	1	1
Water Gasket Fr.	19411-P8A-A03	1	1
Water Gasket Rr.	19412-P8A-A02	1	1



## Replace Parts as Needed

Connecting Rod Bolt:

P/N 13204-P8A-A01

Head Cover Washer:

P/N 90442-P8A-A00

Washer-Bolt (12 x 163):

P/N 90005-PAA-A01

## REQUIRED MATERIALS

Honda Long-Life Antifreeze/Coolant Type 2 (3 gallons)

P/N OL999-9011

Genuine Honda Motor Oil 0W-20 (all models):

P/N 08798-9036 (6 quarts)

or

Genuine Honda Motor Oil 5W-20 (2009-11)  
(if requested)

P/N 08798-9032 (6 quarts)

Hondabond HT (2 tubes)

P/N 08718-0004

Genuine Honda Throttle Plate Cleaner:

P/N 08700-9204

Nylon Parts Cleaning Brush

(commercially available)

5/16 ID Flexible Hose

(commercially available)

## TOOL INFORMATION

Piston Ring Groove Cleaner

T/N 07AAZ-TA5A100

Gasket Remover/Pan Separator:

T/N LIL50190

## WARRANTY CLAIM INFORMATION

### 2009-11 Pilot

NOTE: The procedure in this bulletin is different than the service manual. This procedure does not require the complete removal of the power steering pump, catalytic converter(s), engine and transmission, or the crankshaft. As a result, the operation number is unique and the FRT is reduced.

OP#	Description	FRT
1171G9	<b>Procedure A</b> Update the PCM and replace spark plugs 1-4 (includes diagnosis).	0.5 hr
1171H0	<b>Procedure B</b> Replace piston rings 1-3 and replace spark plugs 1-4 (includes diagnosis).	9.1 hrs
B	Add if replacing piston rings on cylinder 4.	1.9 hrs

Failed Part: P/N 13011-R70-A02

Defect Code: 5V500

Symptom Code: JC000

Skill Level: Repair Technician

### 2012-13 Pilot

NOTE: The procedure in this bulletin is different than the service manual. This procedure does not require the complete removal of the power steering pump, catalytic converter(s), engine and transmission, or the crankshaft. As a result, the operation number is unique and the FRT is reduced.

OP#	Description	FRT
1171G9	<b>Procedure A</b> Update the PCM and replace spark plugs 1-4 (includes diagnosis).	0.5 hr
1171H0	<b>Procedure B</b> Replace piston rings 1-3 and replace spark plugs 1-4 (includes diagnosis).	9.1 hrs
B	Add if replacing piston rings on cylinder 4.	1.9 hrs

Failed Part: P/N 13011-5G0-A01

Defect Code: 5V500

Symptom Code: JC000

Skill Level: Repair Technician

## DIAGNOSIS

1. Connect the HDS to the vehicle and check for the following DTCs: P0301, P0302, P0303, P0304.
  - If any of these DTCs are stored, go to step 2.
  - If none of these DTCs are stored, this bulletin does not apply. Continue with normal troubleshooting.
2. Check the PCM software and note if it is earlier than shown below, then go to step 3 (all 2012 and 2013 vehicles are up to date).

Year/Model	Program ID (or later)	Program P/N (or later)
2009–10 Pilot (2WD)	N0A570	37805–RN0–A57
2009–10 Pilot (4WD)	N0A770	37805–RN0–A77
2011 Pilot (2WD)	N0A630	37805–RN0–A63
2011 Pilot (4WD)	N0A830	37805–RN0–A83

3. Remove and check the spark plug(s) on the affected cylinders (example: if P0301 is stored, check the spark plug on cylinder No. 1).
  - If the spark plug(s) are not fouled, this bulletin does not apply. Continue with normal troubleshooting.
  - If this vehicle has any of the above DTCs, the spark plug(s) are fouled, and the software is an earlier version, go to REPAIR PROCEDURE A.
  - If this vehicle has any of the above DTCs, the spark plug(s) are fouled, and the software is a current or later version, go to step 4.

NOTE: Below are examples of good and fouled spark plugs.

**GOOD**



**NO GOOD**



4. Note which DTCs are stored in the vehicle.
  - If the vehicle has one or more of the following stored DTCs: P0301, P0302, P0303, go to REPAIR PROCEDURE B to clean the pistons, replace the piston rings on the cylinders 1–3, and replace the spark plugs on cylinders 1–4.
  - If the vehicle has DTC P0304 with or without any of the other three DTCs stored, go to REPAIR PROCEDURE B to clean the pistons, replace the piston rings on cylinders 1–4, and replace the spark plugs on cylinders 1–4.

## REPAIR PROCEDURE A

1. Update the PCM software. Refer to Service Bulletin 01-023, *Updating Control Units/Modules*.
2. Replace spark plugs on cylinders 1–4, then return the vehicle to the customer.

## REPAIR PROCEDURE B

The following service manual procedures have been used in full or in part within this service bulletin. For more detail on these procedures, and torque specifications for some components, refer to the appropriate electronic service manual.

- Battery Terminal Disconnection and Reconnection
- Fuel Pressure Relieving
- Fuel Line/Quick-Connect Fitting Removal
- Air Cleaner Removal/Installation
- Splash Shield Replacement
- Drive Belt Removal/Installation
- Engine Oil Replacement
- Coolant Replacement
- Hydraulic Power Steering Fluid Check/Replacement
- Intake Manifold Removal and Installation
- Timing Belt Removal and Installation
- Warm Up TWC Removal/Installation
- Cylinder Head Cover Removal
- Cylinder Head Removal and Installation
- Piston Ring Replacement
- PCM Idle Learn Procedure

### Engine Repair

- Use fender covers to avoid damaging painted surfaces.
  - To avoid damaging any wires and terminals, unplug the circuit connectors carefully while holding the connector portion.
  - Mark all the circuits and hoses to avoid misconnection. Make sure they do not contact other circuit wiring, hoses, or interfere with other parts.
1. Relieve the fuel pressure.
  2. Remove both front wheels so you can fully lower the vehicle.

3. Remove the intake duct.

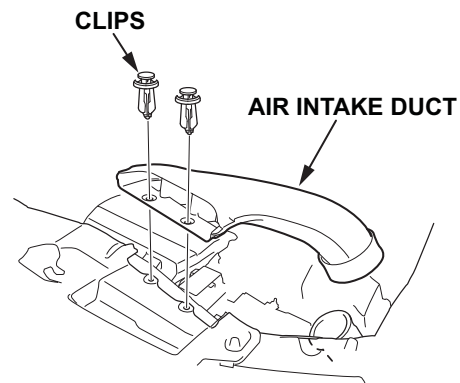

4. Do the battery removal procedure.
5. Disconnect the fuel feed hose line at the bulkhead.

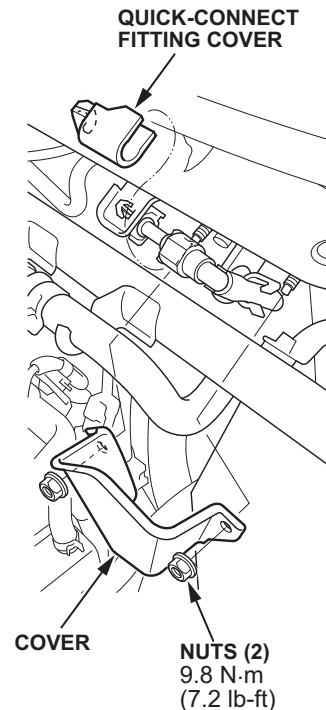

6. Remove the engine cover.

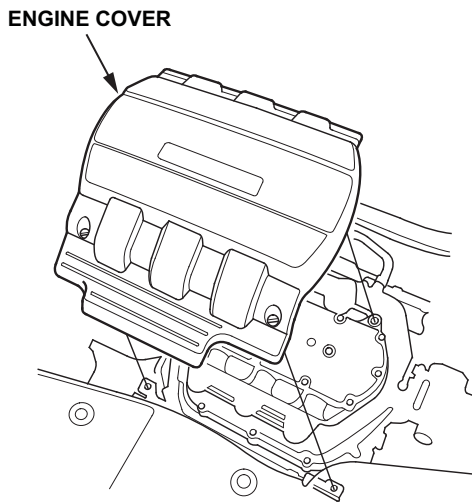

7. Remove the radiator cap.

8. Raise the vehicle.

9. Remove the front splash shield.

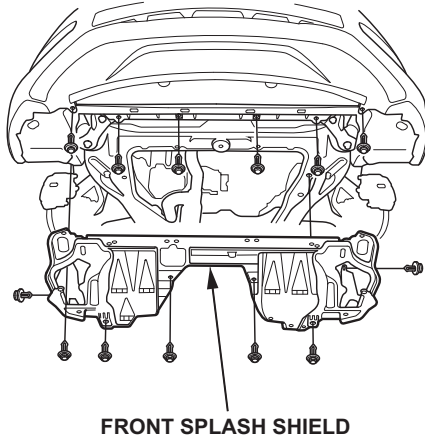

10. Drain the engine oil.

11. Loosen the drain plug on the radiator, and drain the coolant.

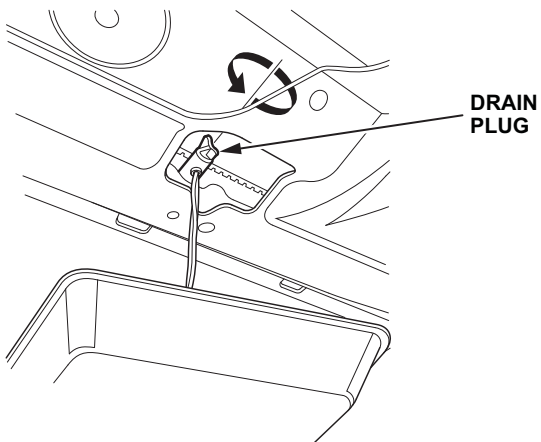

12. Install a 5/16th inner diameter rubber hose on the drain bolt located at the rear of the engine block, loosen the drain bolt, and drain all remaining coolant. Then disconnect the oil pressure switch connector.

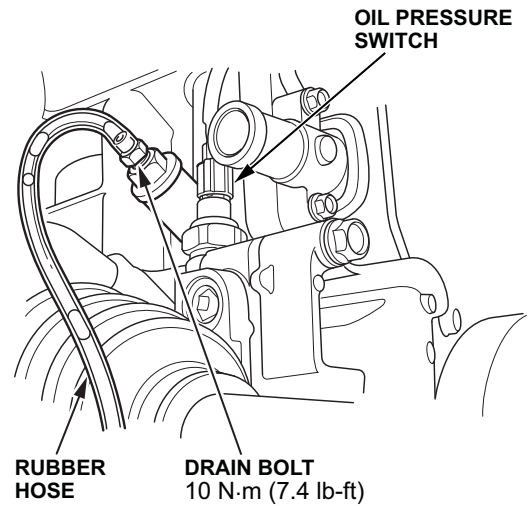

13. Remove the subframe stiffener.

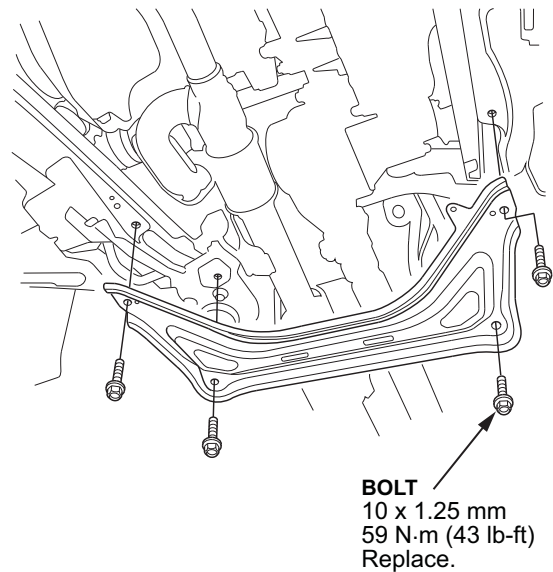

14. Remove exhaust pipe A.

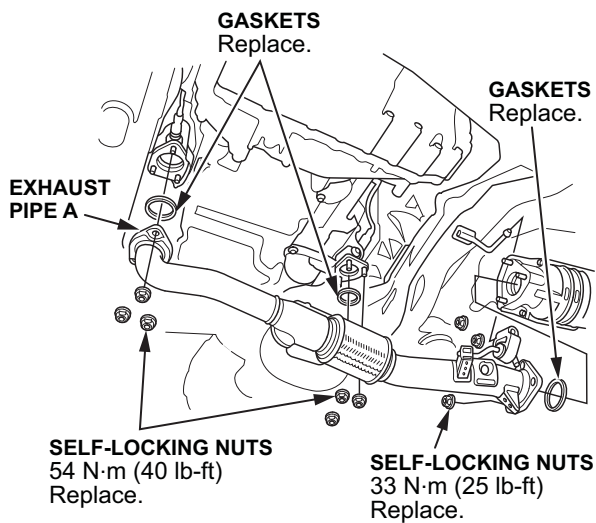

15. Depending on the diagnosis, remove the appropriate WU-TWC support bracket bolts.

16. Remove the EGR lower pipe nuts.

17. Remove the crankshaft pulley bolt but not the pulley.

NOTE: Make sure to apply new oil to the bolt flange and threads before reinstallation.

X : Remove any oil

O : Clean

● : Lubricate with new engine oil

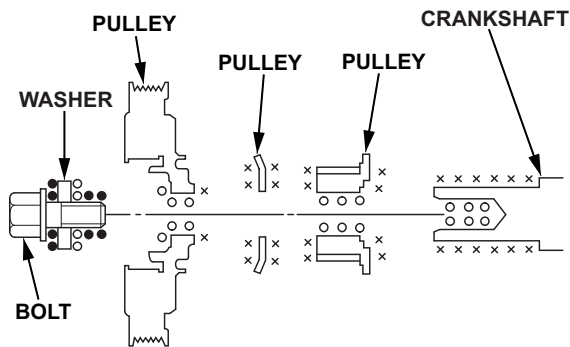

18. Lower the vehicle.

19. Disconnect the MAP sensor connector and the breather pipe, then remove the intake air duct.

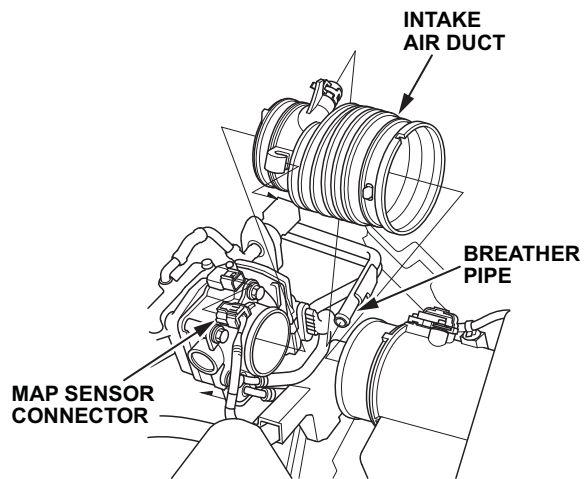

20. Disconnect the throttle body connector, the EVAP canister purge valve connector, the EVAP hose, the brake booster vacuum hose, and the vacuum hose.

21. Disconnect and plug the water bypass hoses.

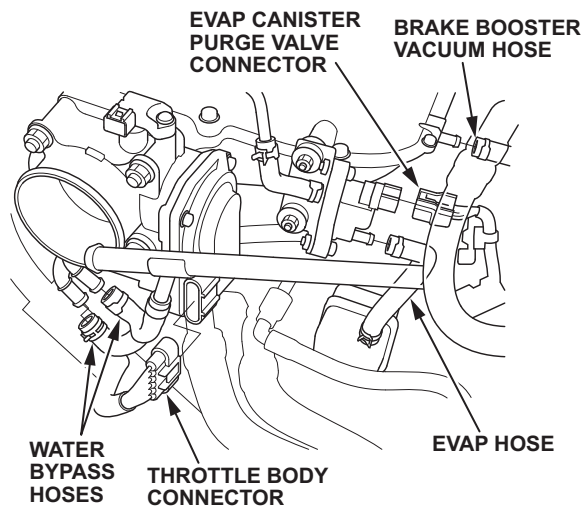

22. Remove the drive belt.

23. Remove the drive belt auto-tensioner.

24. Remove the power steering pump bolts, power steering hose bracket, then secure the power steering pump out of the way.

NOTE: Do not remove any of the hoses.

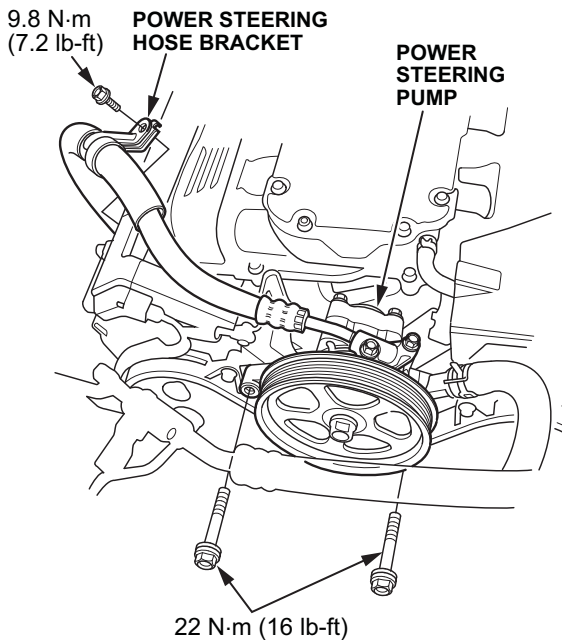

25. Remove the engine harness holder bolt on the side engine mount.
26. Set the engine to TDC cylinder one.
27. Remove the crankshaft pulley.
28. Remove the timing belt.
29. Remove the timing belt idler pulley.
30. Remove the engine intake upper cover bolts and nuts, then remove the cover and PCV hose.

**SPECIFIED TORQUE**  
6 x 1.0 mm  
12 N-m (8.7 lb-ft)

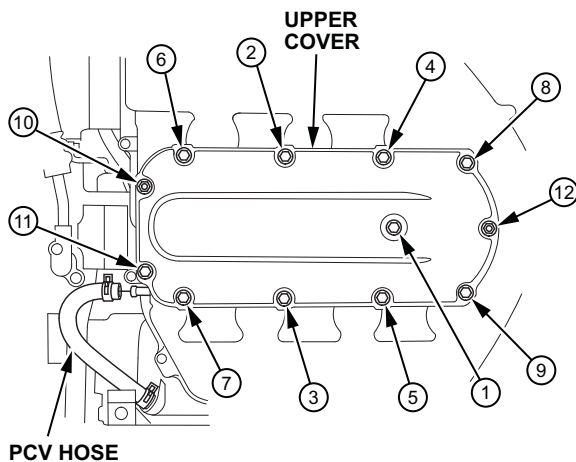

31. Remove the intake manifold bolts and nuts in three steps, then remove the intake manifold.

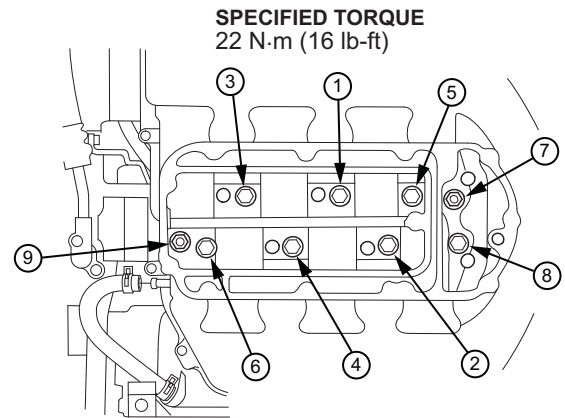

32. Remove the PCM cover and connectors. Disconnect the battery cables from the underhood fuse box.

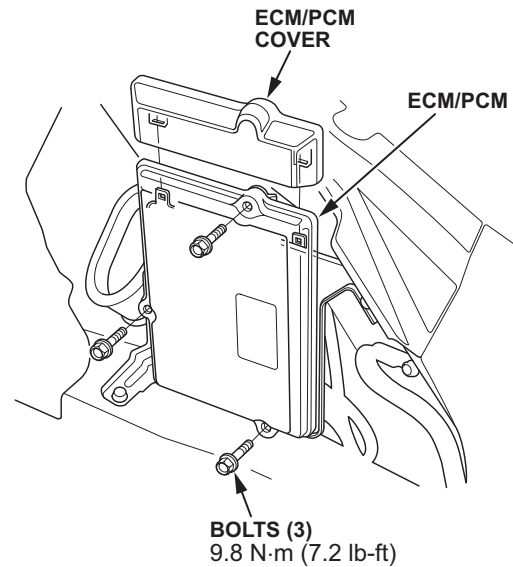



33. Remove the appropriate ignition coils based on the diagnosis.

NOTE: Depending on the diagnosis, you will either have to remove the rear bank ignition coils or both ignition coil banks.

**FRONT**

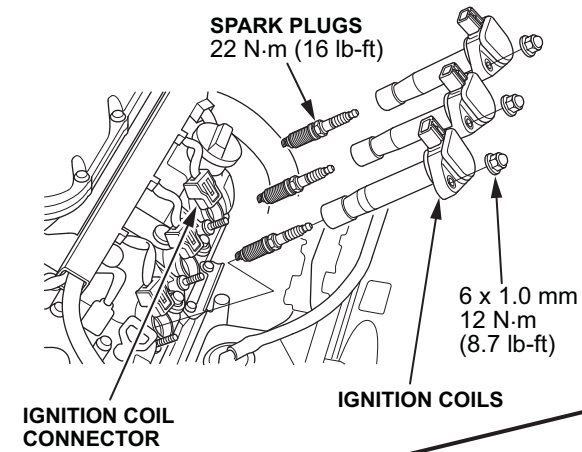

**REAR**

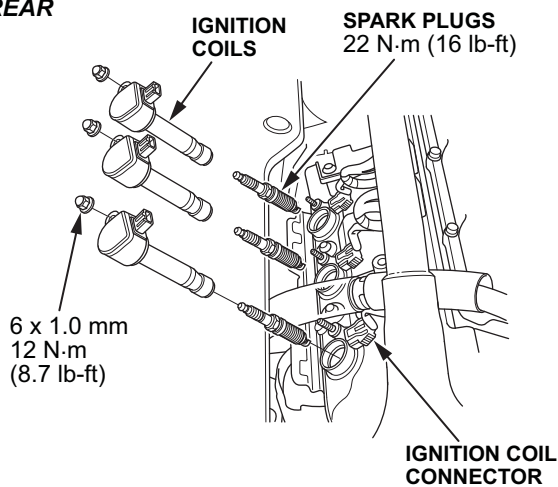

34. Depending on the diagnosis, remove some or all of the following:

- ECT sensor connector
- Front rocker arm oil pressure switch connector
- Rear rocker arm oil pressure switch connector
- CMP sensor connector
- Front A/F sensor one connector
- Rear A/F sensor one connector
- Front secondary HO2S connector
- Rear secondary HO2S connector
- Rocker arm oil control solenoid A connector (bank one)
- Rocker arm oil control solenoid A connector (bank two)
- Rocker arm oil control solenoid B connector (bank one)
- Alternator connector and positive alternator cable
- A/C clutch switch connector
- EGR 5P valve connector
- Engine ground
- Knock sensor
- Fuel injector connectors and clips

35. Remove the quick-connect fitting cover, then disconnect the fuel feed hose.

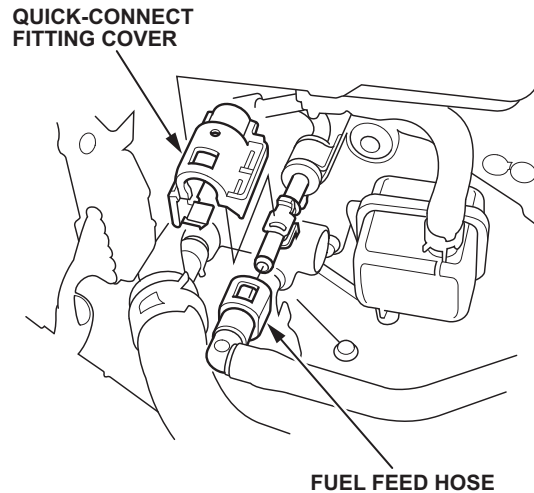



36. Remove the EVAP canister purge joint with the bracket.

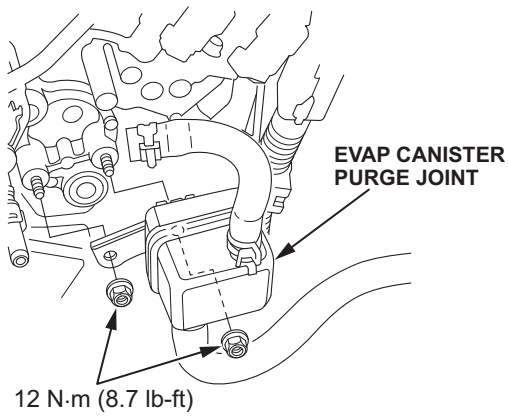

37. Remove the fuel rail connecting joint hose.

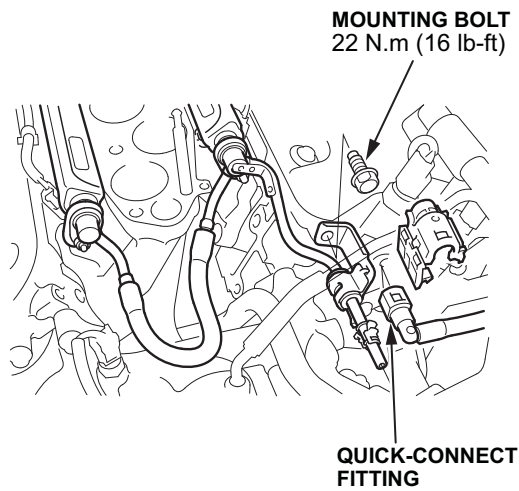

38. Remove the EGR pipe mounting bolts, then remove the EGR pipe.

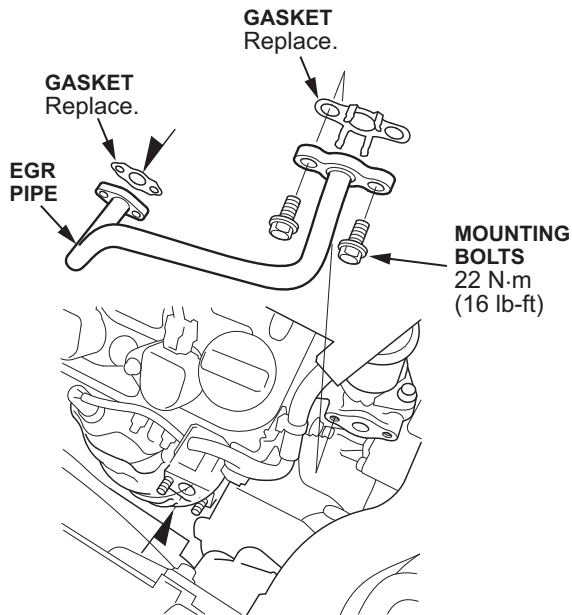

39. Separate the water passage from the heads.

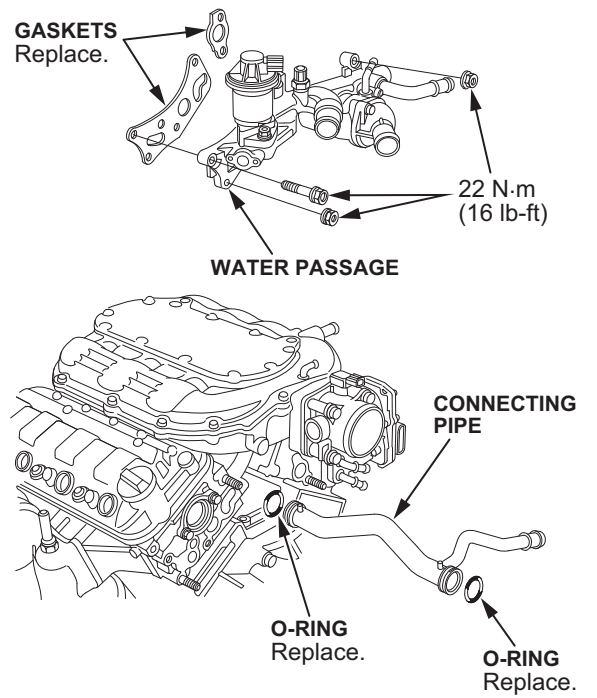

40. Remove the appropriate WU-TWC, depending on diagnosis.

NOTE: Set the WU-TWC aside and cover the opening with shop towels to prevent coolant from entering.

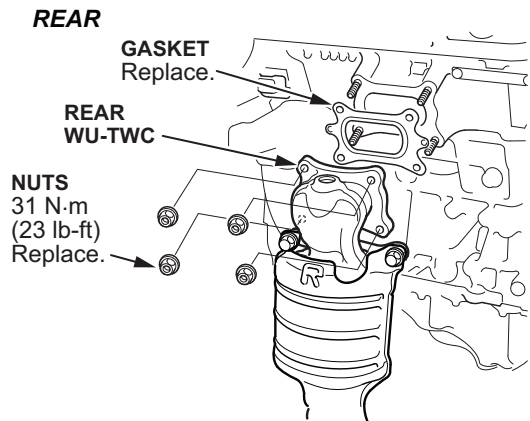
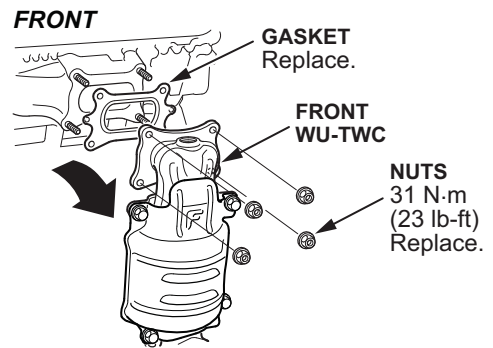

41. Remove the appropriate head with the injector base attached.

NOTE: Depending on diagnosis, you will remove the rear bank head or both heads.

**FRONT**

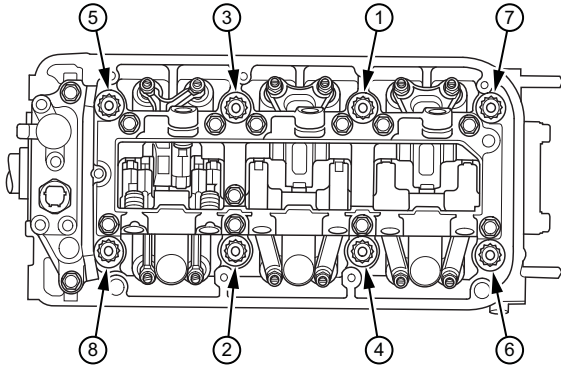

**REAR**

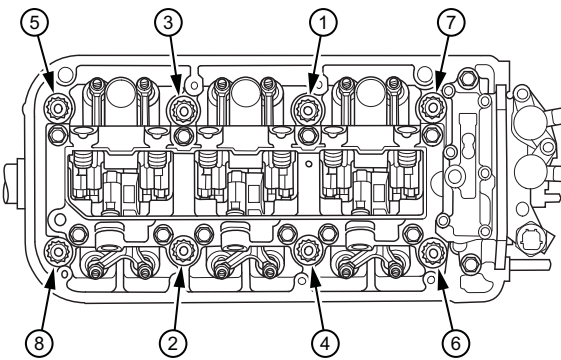

42. Measure the head bolts to determine if they need replacement. If either diameter is less than **11.3 mm (0.445 in)**, replace the cylinder head bolt.

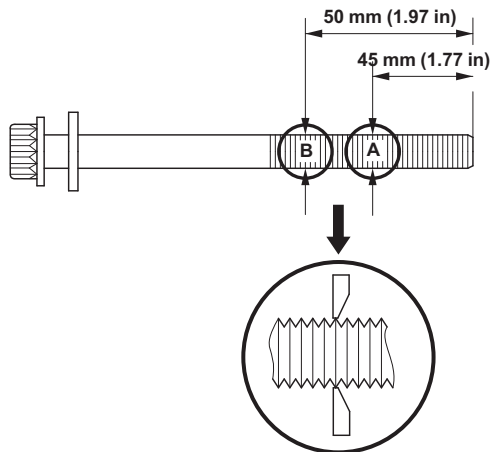

NOTE: Below are the head bolt torque specifications for reinstallation.

- First step: torque the cylinder bolts in sequence to **29 N•m (22 lb-ft)**.
- Second step: tighten in sequence an additional **90 degrees**.
- Third step: tighten in sequence an additional **90 degrees**.
- If the bolts are new, tighten an additional **90 degrees**.

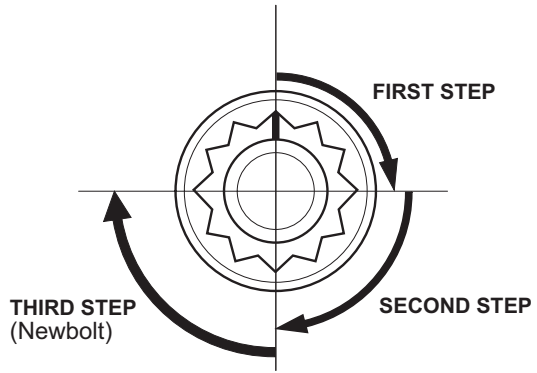

43. Raise the vehicle.

44. Remove the CKP sensor cover and bolts, then disconnect the CKP sensor connector.

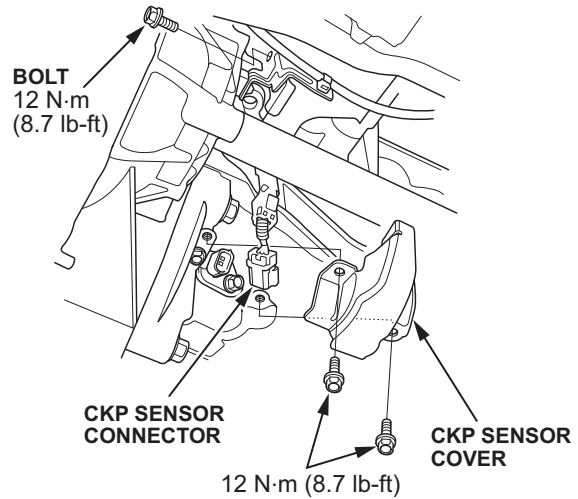

45. Remove the torque converter case cover and the four bolts securing the oil pan to the transmission.

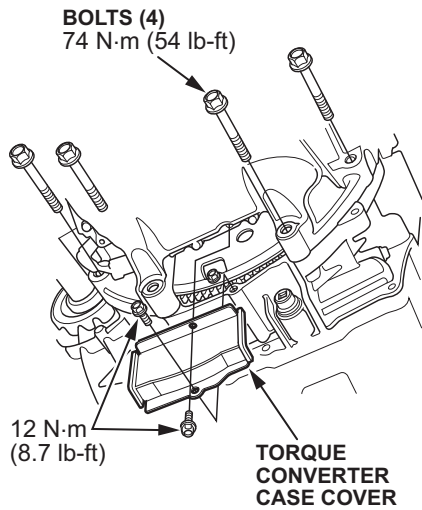

46. Remove all bolts securing the oil pan.

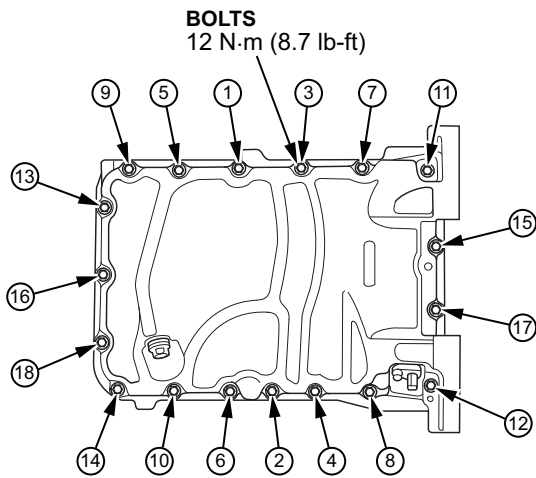

47. Using a flat blade screwdriver, separate the oil pan from the engine block in the areas shown.

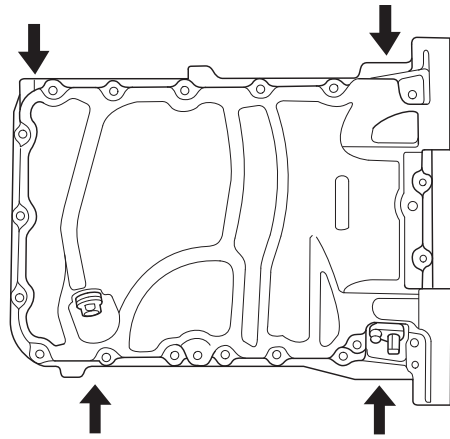

48. Remove the oil strainer and baffle plate.

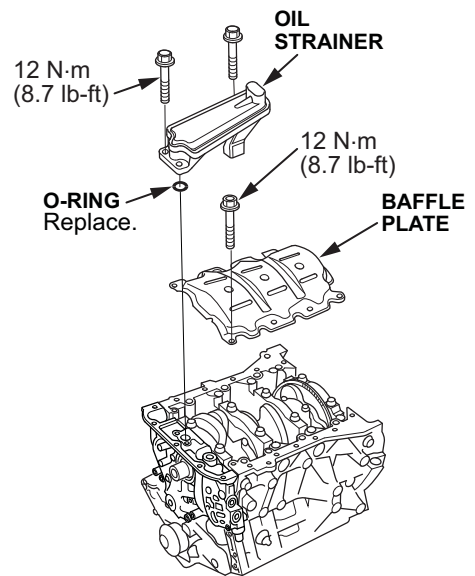

49. Remove the appropriate pistons depending on diagnosis, then go to **PISTON CLEANING PROCEDURE**.

**NOTE:** When removing the piston rod caps, be sure to keep all caps and bolts with their corresponding pistons for reassembly purposes.

## PISTON CLEANING PROCEDURE

1. Remove the piston rings from the piston using a ring expander. Be careful not to damage the piston.

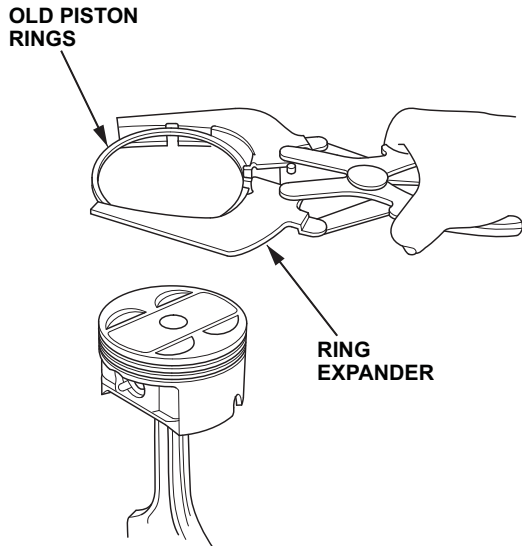

2. Spray the piston head and piston ring grooves thoroughly with Honda throttle plate cleaner.
3. While holding the piston upright in your left hand, take the piston ring groove cleaner tool in your right hand and line up the cleaner tool guides with the second (middle) piston ring groove.



4. Press the handle on the piston ring groove cleaner tool and slide the cleaning bit onto the appropriate piston ring grooves.



5. Once the cleaning bit is in the appropriate ring grooves of the piston, make sure the tool handle clicks in to place.

NOTE: There is only one notch on the tool for the handle to engage.

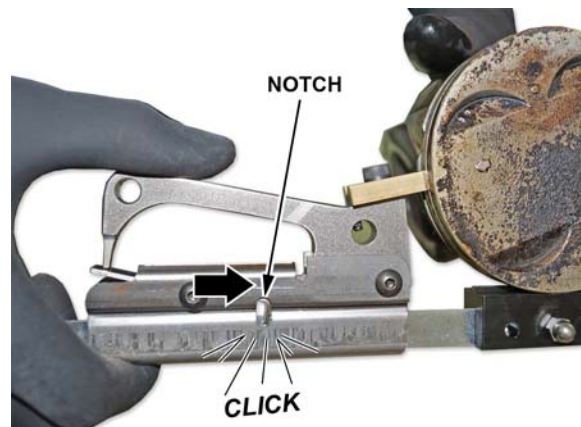



6. Hold the piston steady and rotate the tool counter-clockwise five to six times to remove any carbon deposits in the piston ring grooves. **Do not** rotate the tool clockwise.

NOTE: You can watch this procedure in the *Tech2Tech* segment "How to Clean Piston Ring Grooves".

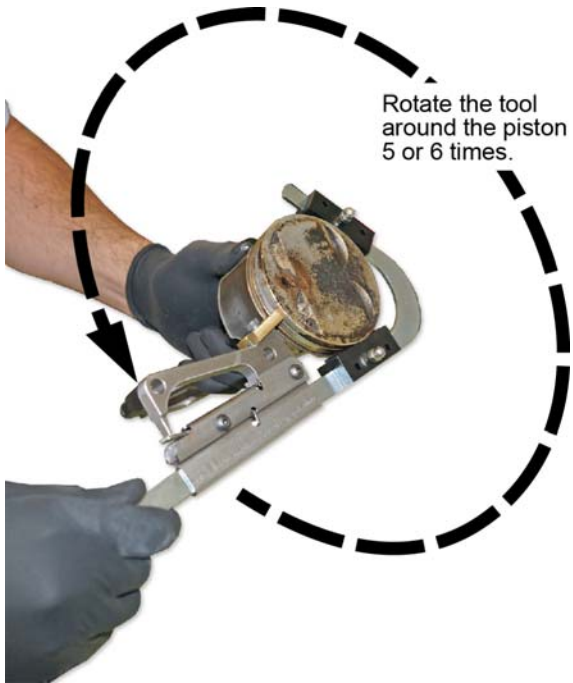

7. Remove the piston groove cleaning tool and clean off the carbon from the tool bit.
8. Finish cleaning the piston with throttle plate cleaner and the nylon brush. **Do not** use a steel wire brush.



NOTE: Below are some examples of before and after pictures. Depending on mileage and running conditions, the pistons will achieve different levels of cleanliness.

#### 54K PISTON



#### 87K PISTON

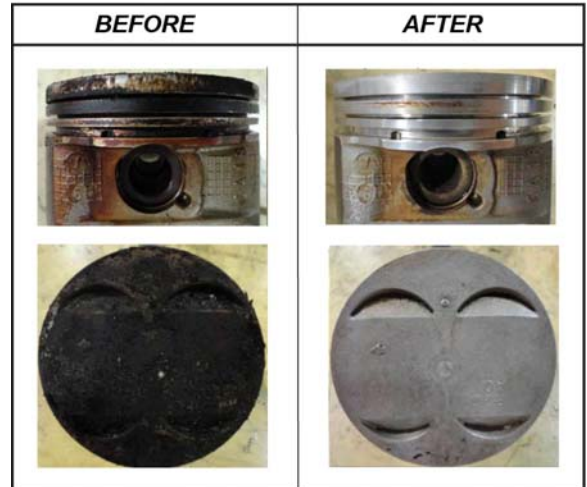

9. Install the piston rings as shown.

NOTE: The first (top) ring has a 1D manufacturing mark and the second (middle) ring has a 2X manufacturing mark. The manufacturing marks must be facing upward.

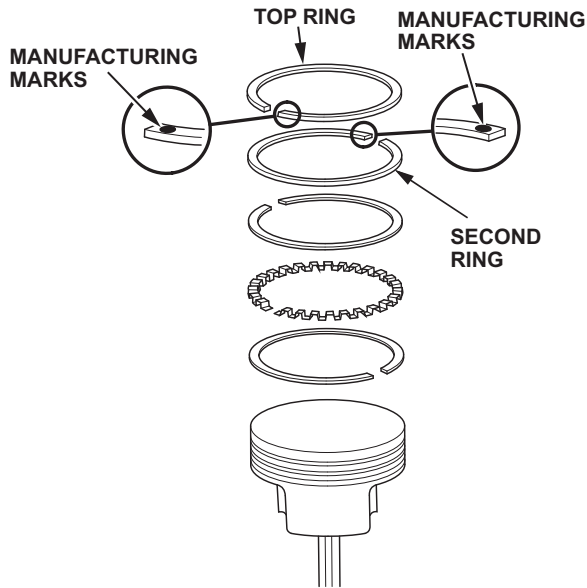
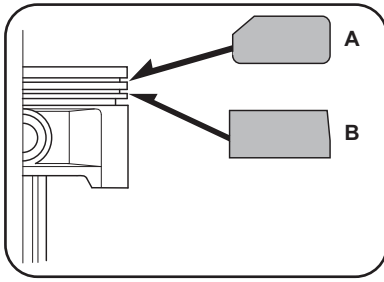

10. Position the ring end gaps as shown.

NOTE: If the ring gaps are not positioned correctly, excessive blowby may occur.

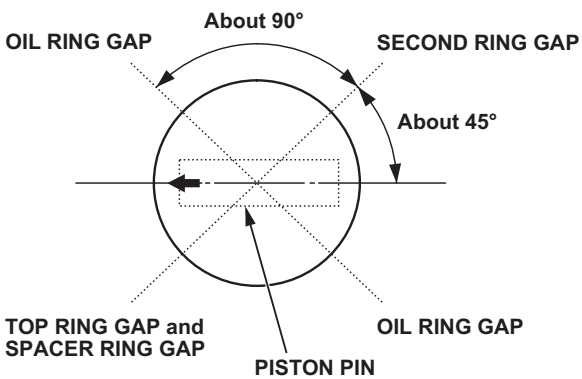

11. Apply new engine oil to the piston, the inside of the piston ring compressor, and the cylinder bore.

12. Install the piston/connecting rod assembly in to the cylinder bore with the arrow on top of the piston facing the timing belt side of the engine.

NOTE: Be careful not to damage the cylinder wall when installing the piston.

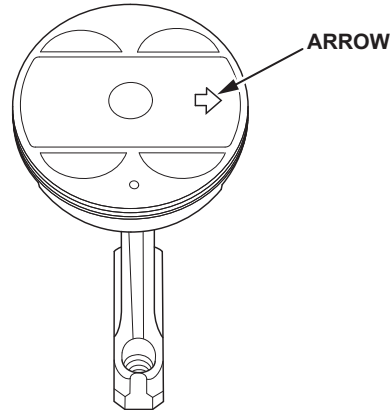

13. Measure the diameter of the connecting rod bolts to determine if they need replacement. Calculate the difference in diameter between point A and point B. It should not be more than 0–0.1 mm (0–0.004 in).

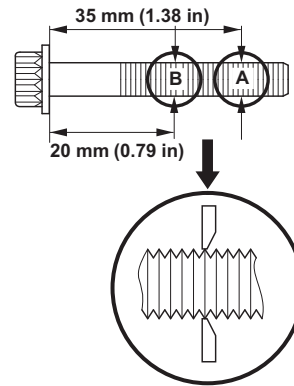

14. Apply new oil to the connecting rod bolt threads and flanges. Torque the bolts to **20 N·m (14 lb-ft)**, then tighten the connecting rod bolts an additional **90 degrees**.

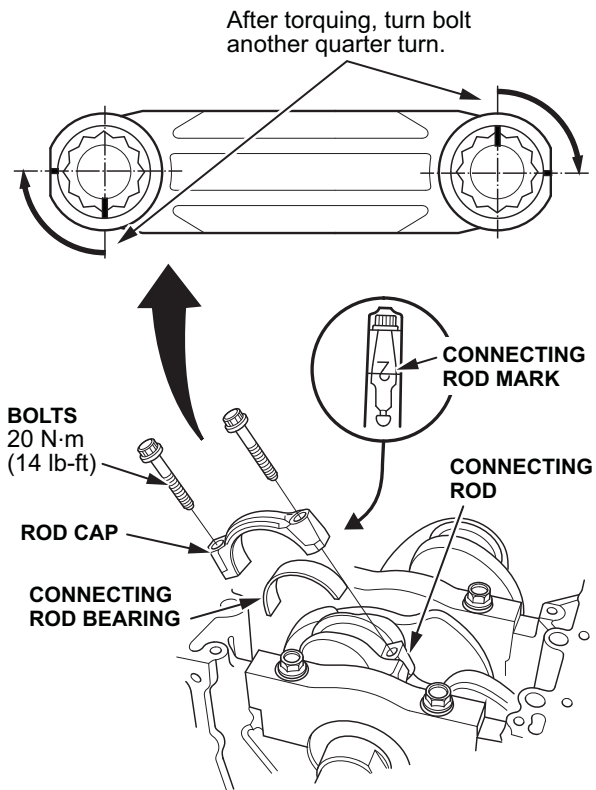

15. Reinstall the remaining components in the reverse order of removal.
16. Replace spark plugs 1–4.
17. Replace the oil filter and refill all fluids.
18. Do the idle learn procedure.