

Auto Codes >>> <https://www.autocodes.com>

P1078 HONDA - Intake Manifold Runner Control System Malfunction High RPM

Possible causes Faulty Intake Manifold Runner Control (IMRC) Valve IMRC Valve harness is open or shorted IMRC Valve circuit poor electrical connection

Possible symptoms Engine Light ON (or Service Engine Soon Warning Light)

P1078 HONDA Description Engine power is achieved by closing and opening the Intake Manifold Runner Control (IMRC) valve. When the valve is closed, there is high torque at low engine speed. When the valve is open, there is high torque a high engine speed.

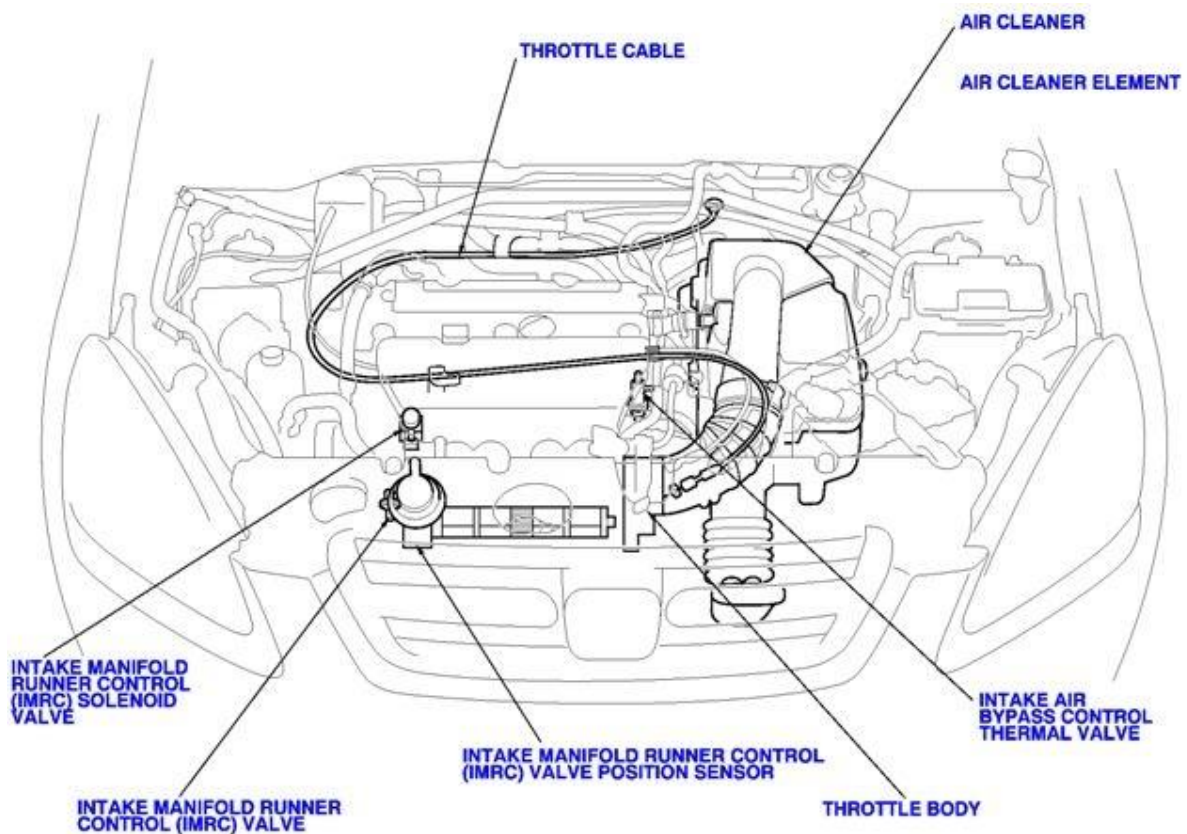

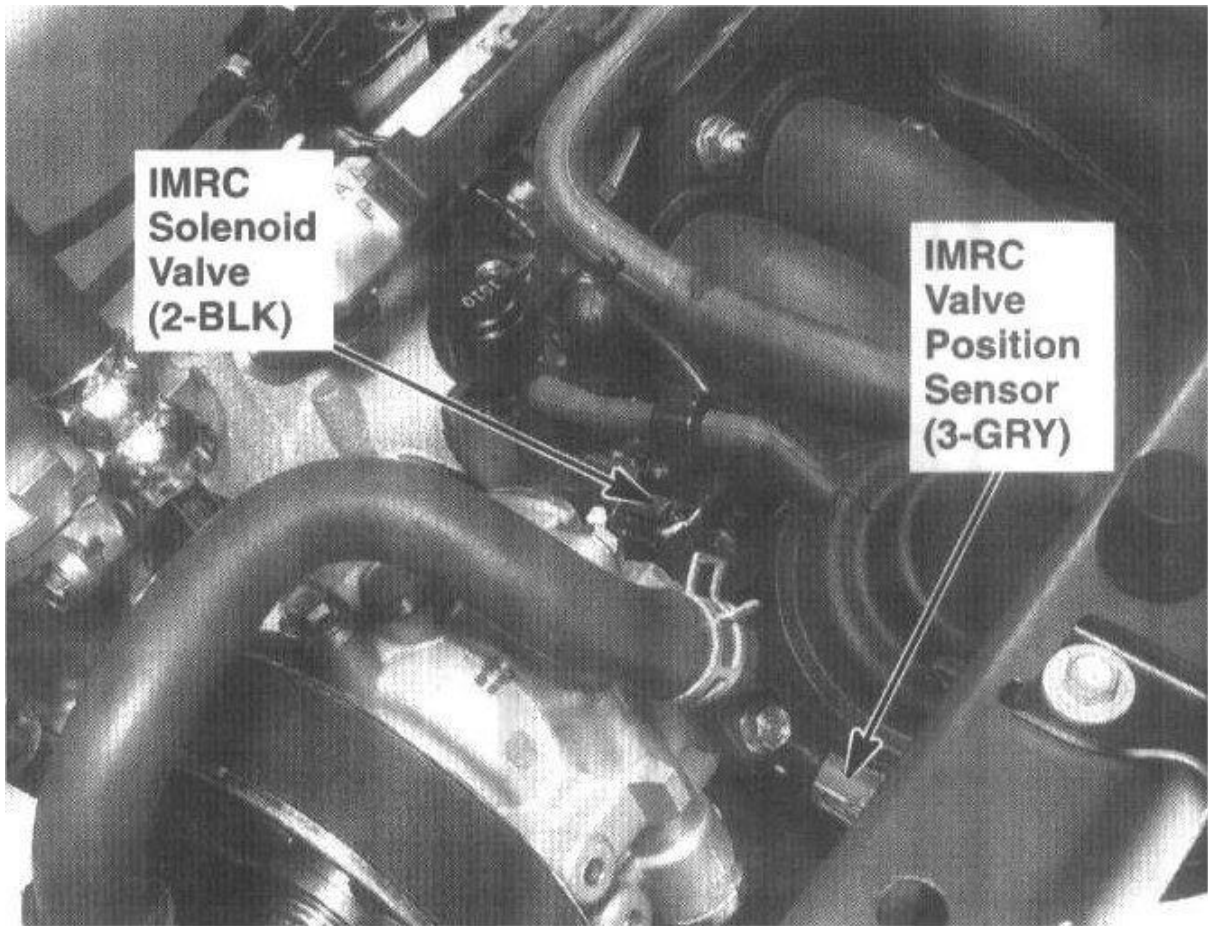

**IMRC
Solenoid
Valve
(2-BLK)**

**IMRC
Valve
Position
Sensor
(3-GRY)**