

Engine Removal/Installation

(cont'd)

24. Remove the upper and lower radiator hoses and the heater hoses.

B16A2 engine:

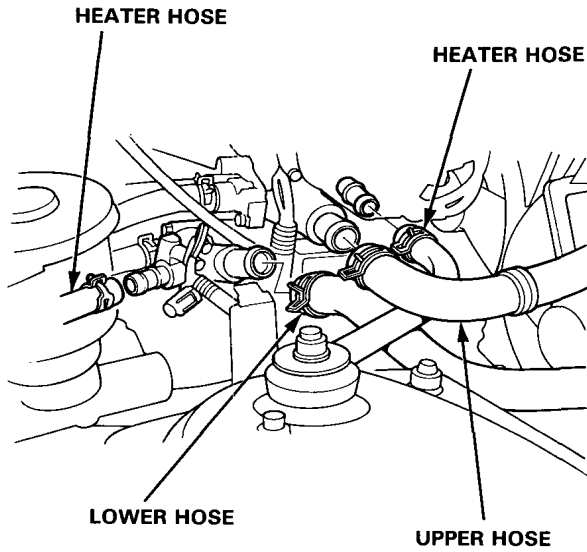

Except B16A2 engine:

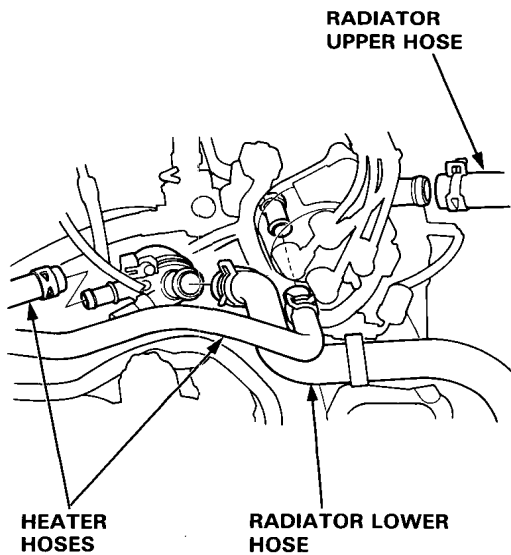

25. Remove the A/T shift cable.

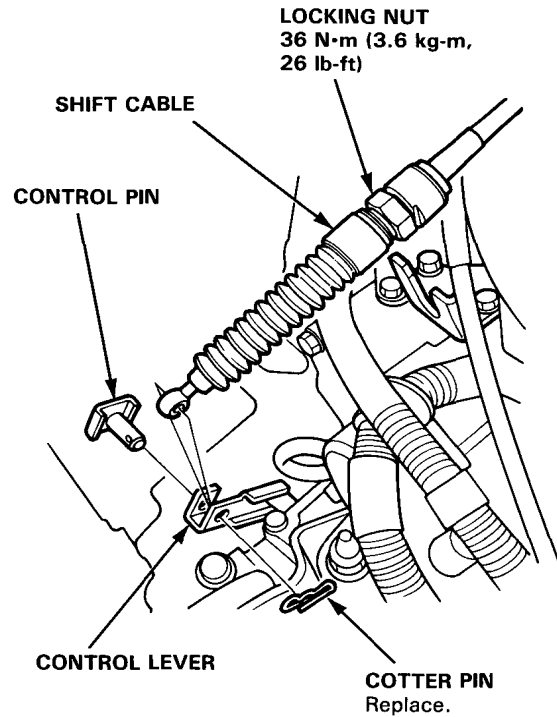

26. Remove the shift cable and select cable (M/T 4WD).

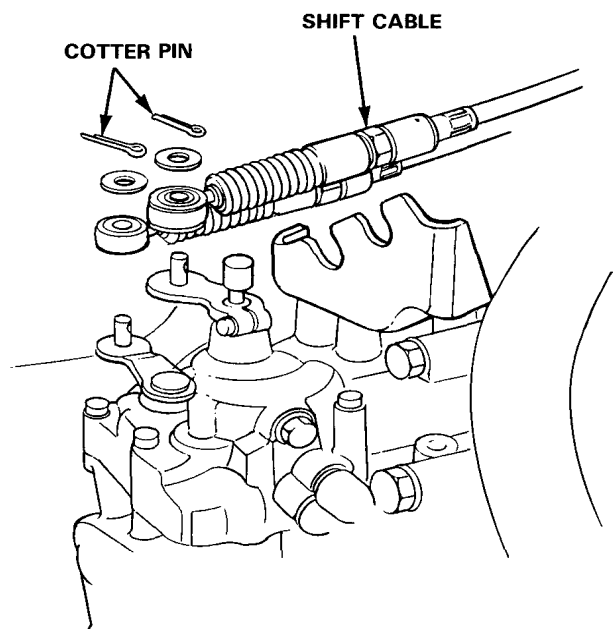



27. Raise the hoist to full height.

28. Remove the exhaust pipe and stay.

Single type:

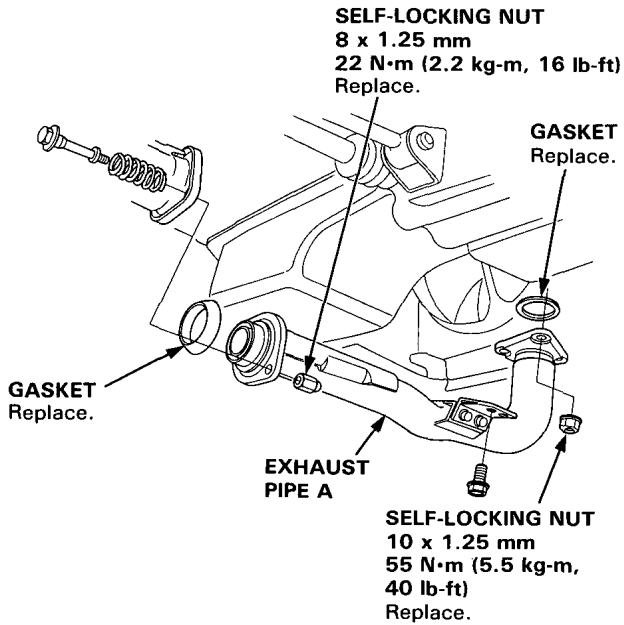

Dual type:

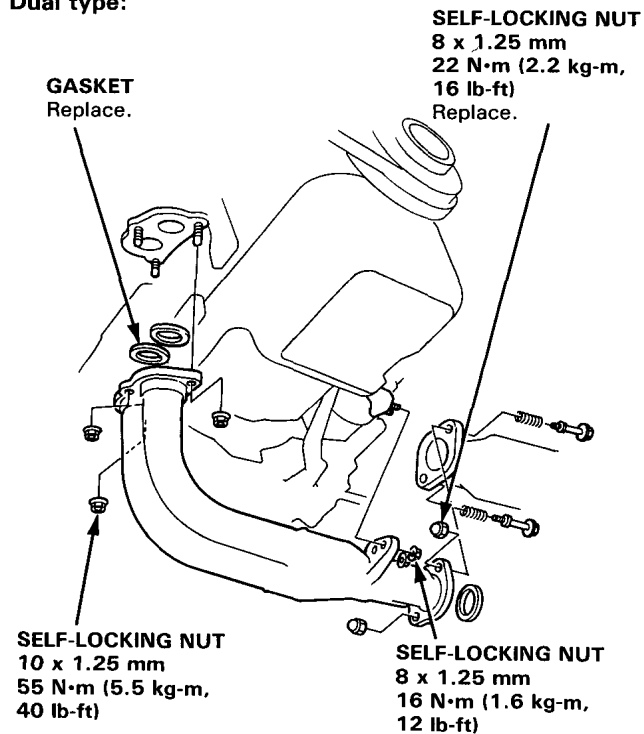

29. Remove the A/T shift cable (A/T).

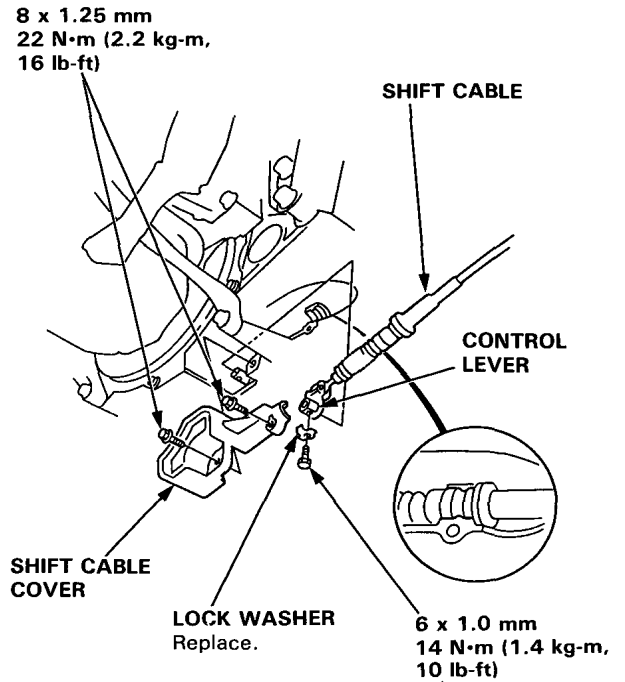

30. Remove the clutch slave cylinder and pipe/hose assembly (M/T).

- Do not disconnect the pipe/hose assembly.

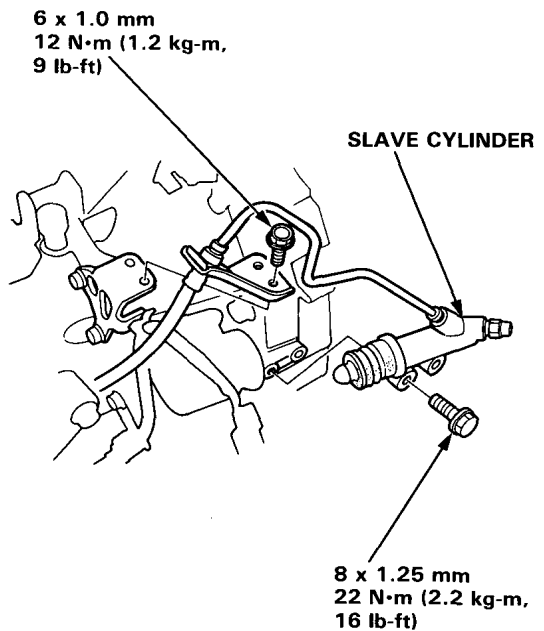

(cont'd)

Engine Removal/Installation

(cont'd)

38. Remove the left and right front stopper rubbers and stopper brackets.

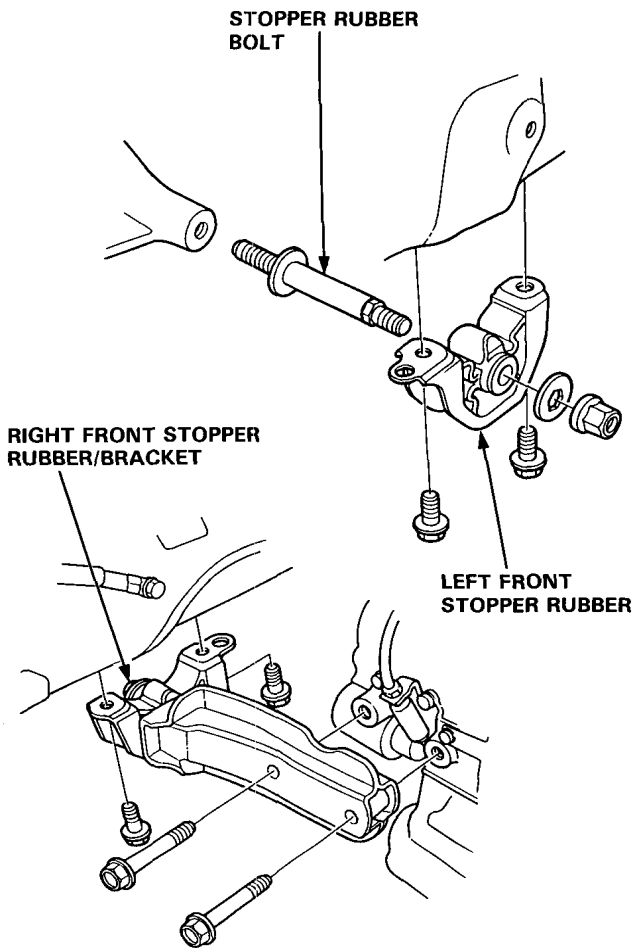

39. Remove the rear engine mounting bracket.

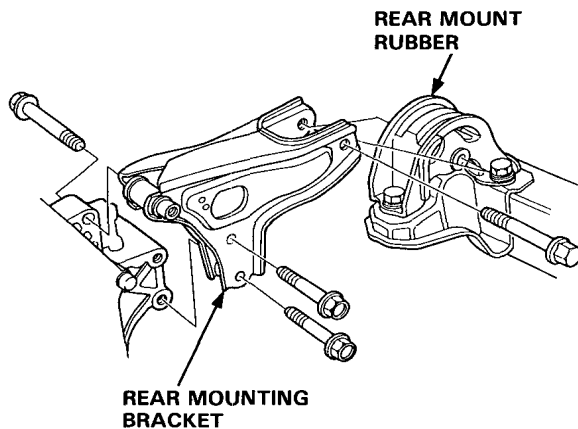

40. Remove the engine support nuts. Loosen the mount bolt and pivot the engine side mount out of the way.

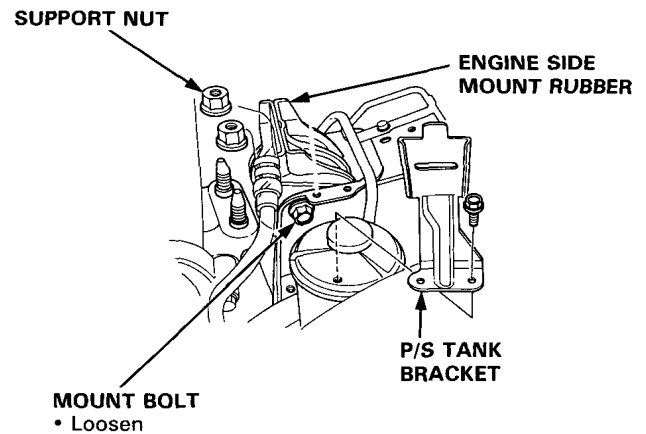

41. Remove the transmission mount nuts. Loosen the mount bolt and pivot the transmission side mount out of the way.

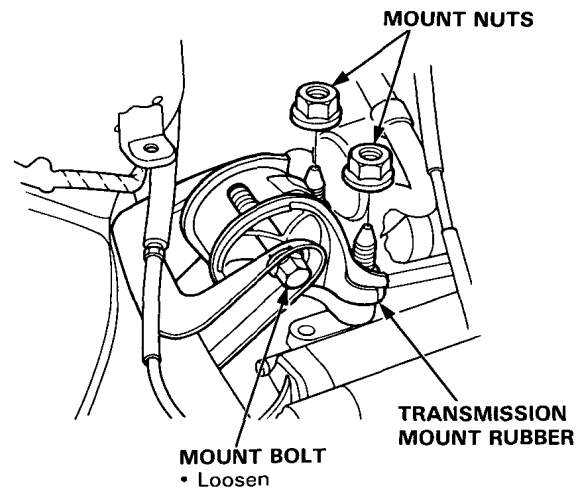

42. Raise the chain hoist to remove all slack from the chain.
43. Check that the engine is completely free of vacuum hoses, fuel and coolant hoses, and electric wires.
44. Slowly raise the engine approximately 150 mm (6"). Check once again that all hoses and wires have been disconnected from the engine.
45. Raise the engine all the way and remove it from the car.



46. Install the engine in the reverse order of removal.

NOTE:

After the engine is in place:

- Torque the engine mounting bolts in sequence shown below.

CAUTION: Failure to tighten the bolts in the proper sequence can cause excessive noise and vibration, and reduce bushing life; check that the bushings are not twisted or offset.

- Check that the spring clip on the end of each driveshaft clicks in to place.

CAUTION: Use new spring clips on installation.

- Bleed air from the cooling system at the bleed bolt with the heater valve open.
- Adjust the throttle cable tension.
- Check the clutch pedal free play (M/T).
- Check that the transmission shifts into gear smoothly.

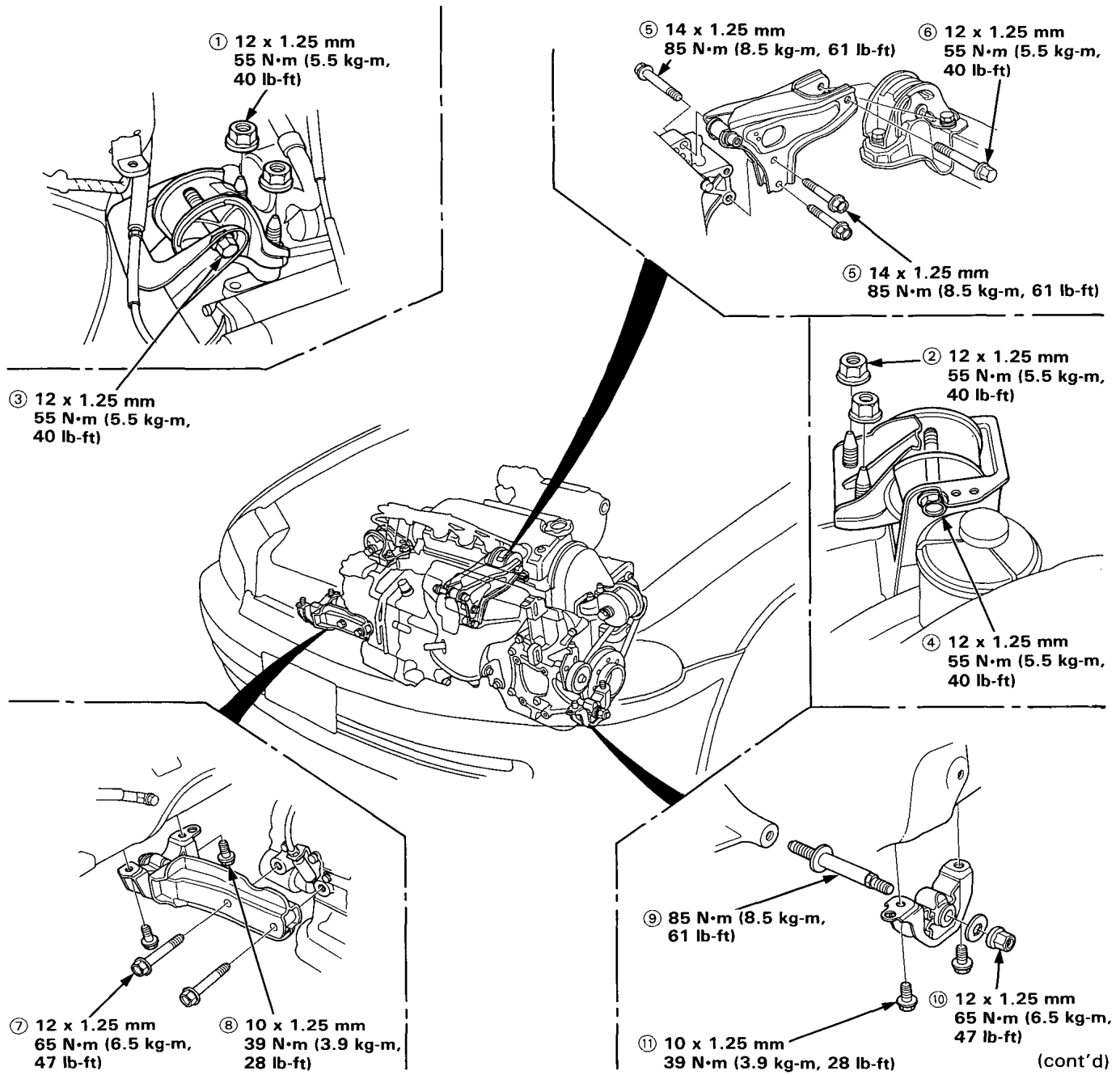

(cont'd)