



Applies To: **1998-00 Accord V6** – ALL  
**2001 Accord V6** – 4-door from VIN 1HGCG1...1A000001 thru 1HGCG1...1A058564  
 – 2-door from VIN 1HGCG2...1A000001 thru 1HGCG2...1A023388

October 26, 2001

## Accord Warranty Extension: EGR Port Clogging

(Supersedes 99-085, *Product Update Campaign: PCV Hose Routing*, dated March 21, 2000)

### BACKGROUND

In some areas of the U.S., certain basic chemical properties of gasoline (regardless of brand) may cause the intake manifold EGR port to clog or the EGR valve to fail. If this happens, the MIL comes on with a DTC P0401 (insufficient EGR flow) or P1491 (insufficient EGR lift) stored.

### WARRANTY EXTENSION INFORMATION

This warranty extension cancels the PCV hose routing Product Update Campaign. You should no longer install the PCV hose routing kit.

American Honda is extending the warranty on EGR system problems in the affected vehicles to 8 years or 80,000 miles, whichever comes first. To be eligible for coverage under this extended warranty, the MIL must be on with one of the above DTCs stored. Install the EGR pipe kit, and file a claim using the information in this service bulletin.

### CUSTOMER NOTIFICATION

**1998-99 vehicles** – Owners of vehicles that were subject to the PUD will be mailed a letter explaining that the PUD has been cancelled, and detailing the 8 year, 80,000 mile warranty extension covering EGR system clogging.

**1999-01 vehicles** – The original PUD applied to V6 Accords through the first part of the 1999 model year. This warranty extension adds the remainder of the 1999 model year, all of 2000, and part of the 2001 model year. Owners of vehicles that were not involved in the original PUD will be mailed a letter detailing the 8 year, 80,000 mile warranty extension covering EGR system clogging.

Examples of the customer notifications are at the end of this service bulletin.

### CORRECTIVE ACTION

Clean the EGR port, and install the EGR pipe kit.

### PARTS INFORMATION

EGR Pipe Kit: P/N 06175-P8C-A00, H/C 6912125

### TOOL INFORMATION

EGR Pipe Installation Kit: T/N 07ZAD-P8AA000

Kit Contents:

EGR Pipe Installation Tool – T/N 07ZAD-P8AA100

Drill Bit – T/N 07ZAH-P8AA100

### WARRANTY CLAIM INFORMATION

**In warranty:** The normal warranty applies.

Operation Number: 120122

Flat Rate Time: 1.5 hours

Failed Part: P/N 17100-P8A-A00  
H/C 5232749

Defect Code: 537

Contention Code: L37

Template ID: 99-085C

Skill Level: Repair Technician

**Out of warranty:** Any repair performed after warranty expiration may be eligible for goodwill consideration by the District Service Manager or your Zone Office. You must request consideration, and get a decision, before starting work.

### REPAIR PROCEDURE

1. Remove the throttle body cover, intake manifold covers, ignition wire holder, and ignition wire cover.

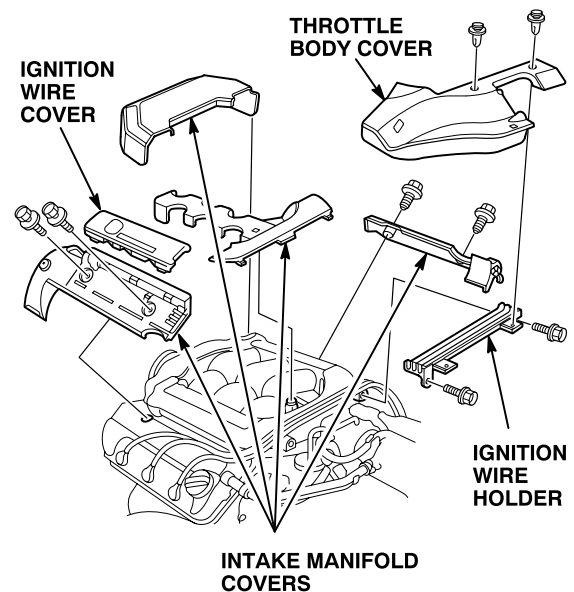

2. Disconnect the brake booster vacuum hose and the vacuum hose from the intake manifold.

- Remove the throttle body from the intake manifold (two nuts and two bolts). Leave all hoses, cables, and electrical connectors connected to the throttle body. Discard the throttle body gasket.

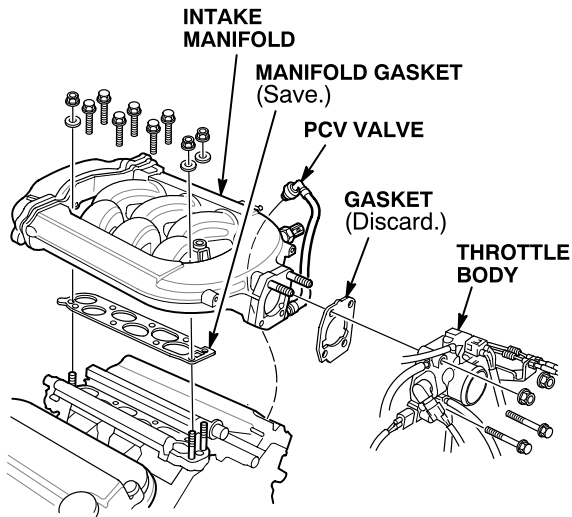

- Remove the PCV valve from the cylinder head cover. Remove the intake manifold (three nuts and six bolts).
- Remove the intake manifold chamber, IAT sensor, boost plate, and PCV hose from the intake manifold.

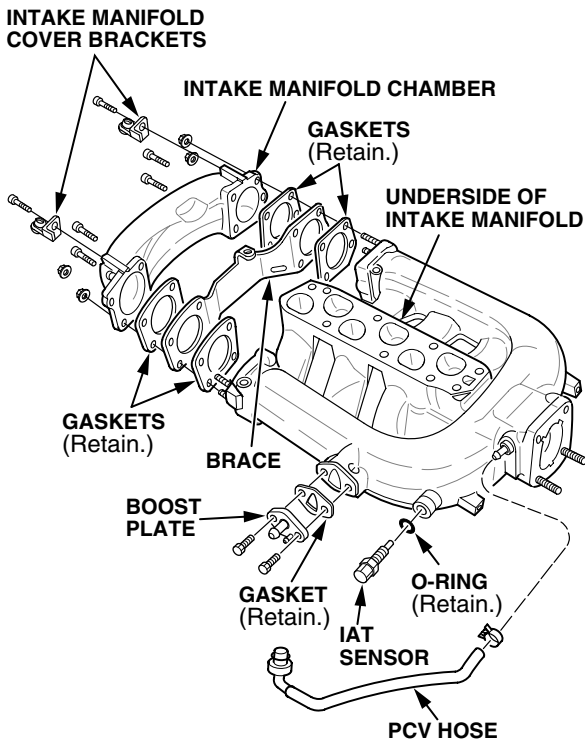

- Cover the six ports on the bottom of the manifold with duct tape.

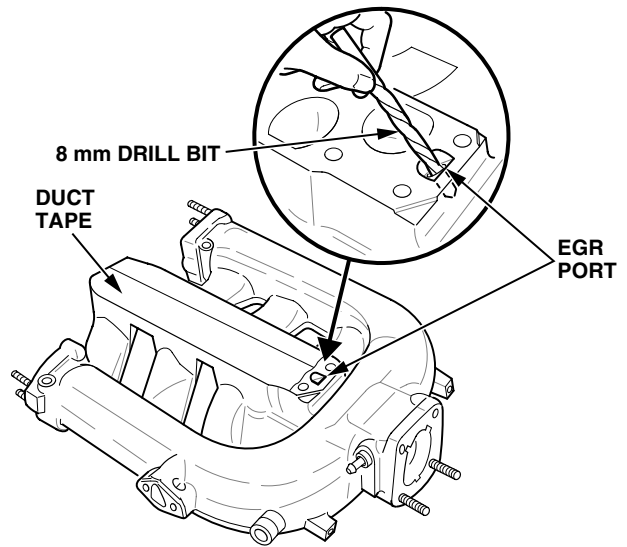

- Use an 8-mm drill bit and carburetor cleaner to clean the EGR port in the intake manifold. Turn the drill bit only by hand. Do not use a power drill.
  - Put the special drill bit from the EGR pipe installation kit in your power drill. Coat the drill bit completely with clean engine oil.
- NOTE: The oil coating is critical to drilling the hole accurately, and it contributes to drill bit life.
- Insert the guide part of the drill bit into the EGR port. Make sure it is inserted fully. Then drill out the EGR port using steady pressure on the drill. Make sure the port is drilled through completely.

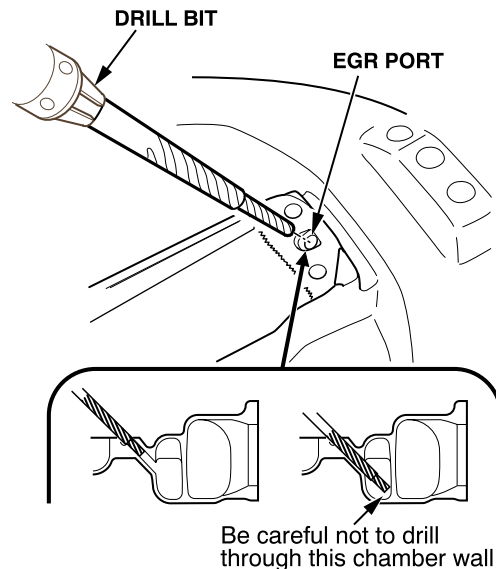

- Clean up the aluminum chips from drilling, then remove the duct tape.

11. Put the manifold in a parts washer (solvent or soap and water) and clean it thoroughly.
  - Flush out the EGR port for 20 seconds.
  - Flush out the manifold from the throttle body opening. Run cleaner down each side for 20 seconds.
  - Flush each intake runner for 10 seconds. Start at the throttle body end and work towards the back.
  - Turn the manifold so the throttle body opening is facing down. Flush each main runner for 20 seconds.
  - Dry the manifold with compressed air and clean shop towels.

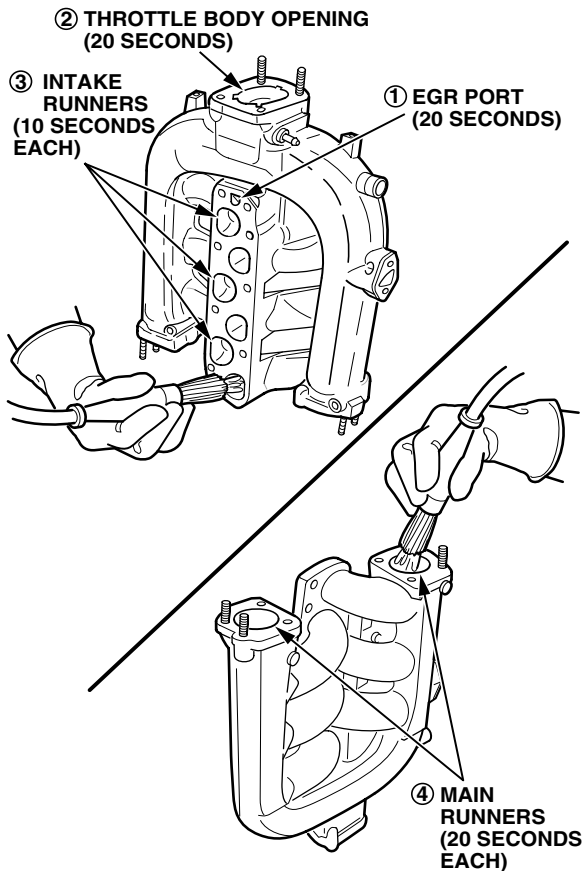

12. Place the EGR pipe from the kit into the EGR port.

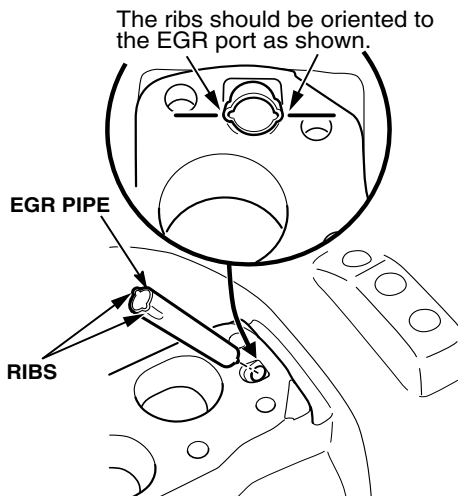

13. Use the installation tool and a small hammer to drive the EGR pipe into the port until it is flush with the port. Make sure the pipe will not contact the gasket after installation.

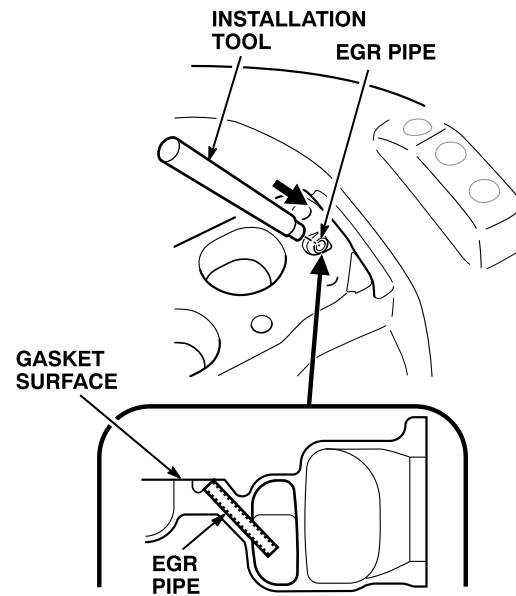

14. Install the intake manifold chamber; torque the nuts and bolts to 12 N·m (8.7 lb-ft). Install the IAT sensor; torque it to 18 N·m (13 lb-ft). Install the boost plate; torque the bolts to 12 N·m (8.7 lb-ft). Install the PCV hose.
15. Inspect the EGR port in the front of the injector base on the engine. If it is partially or fully clogged, clean the port.
16. Disconnect the 6P connector from the EGR valve. Remove the EGR valve.

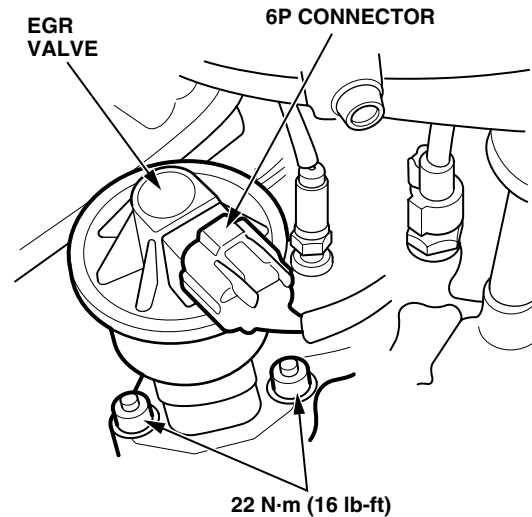

17. Install the new EGR valve with a new gasket. Torque the mounting nuts to 22 N·m (16 lb-ft). Reconnect the 6P connector.

18. Install the intake manifold with the original gasket. Torque the mounting nuts and bolts to 22 N·m (16 lb-ft) sequentially in two or three steps. Route the PCV hose so it is not pinched under the intake manifold.

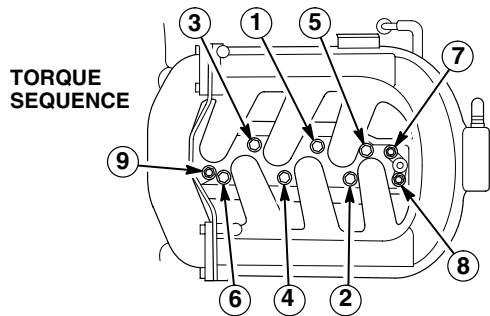

19. Install the PCV valve in the cylinder head cover.
20. Install the throttle body with a new gasket. Torque the mounting nuts and bolts to 22 N·m (16 lb-ft).
21. Reinstall the brake booster vacuum hose, vacuum hose, ignition wire holder, and all of the covers.
22. Connect the PGM Tester (loaded with SN200 or later software). Clear any DTCs.
23. Use the PGM Tester to override two-trip error detection.
- From the PGM tester menu, select *1. Honda Systems*.
  - Then select *2. SCS*.
24. Test-drive the vehicle to make sure no new DTCs are set.

**Example of Customer Letter (1998–99 Accord subject to the original PCV Hose Routing Campaign)**

November 2001

**Warranty Extension: EGR System Clogging**

Dear Accord Owner:

Early last year, you should have been notified of a Product Update Campaign involving the Positive Crankcase Ventilation (PCV) system and the Exhaust Gas Recirculation (EGR) system on your vehicle's engine. The EGR system could become clogged, causing the Malfunction Indicator Lamp (Check Engine light) to come on.

**Warranty Extension Details**

After studying the causes and frequency of EGR system clogging, American Honda has decided to cancel the Product Update Campaign. To provide protection in the unlikely event your vehicle should experience this problem, the warranty coverage for EGR system clogging is being extended to 8 years or 80,000 miles, whichever comes first. If the Check Engine light should come on, take your vehicle to any Honda dealer. If they determine that the cause is clogging of the EGR system, they will repair it at no charge for parts or labor.

**What to do if you feel this notice is in error**

Our records show that you are the current owner of a 1998–99 Accord. If this is not the case, or the name/address information is incorrect, please fill out and return the enclosed, postage-paid *Information Change Card*. We will then update our records.

**If you have questions**

If you have questions about this notice, please call Honda Automobile Customer Service at (800) 999-1009.

Sincerely,

**American Honda Motor Co., Inc.  
Honda Automobile Division**

**Example of Customer Letter (1999–01 Accord not subject to the original PCV Hose Routing Campaign)**

November 2001

**Warranty Extension: EGR System Clogging**

Dear Accord Owner:

In some areas of the U.S., certain basic chemical properties of gasoline (regardless of brand) may cause the Exhaust Gas Recirculation (EGR) port in the engine's intake manifold to become clogged or the EGR valve to fail. If this happens, the Malfunction Indicator Lamp (Check Engine light) will come on.

**Warranty Extension Details**

To provide protection in the unlikely event your vehicle should experience this problem, the warranty coverage for EGR system clogging is being extended to 8 years or 80,000 miles, whichever comes first. If the Check Engine light should come on, take your vehicle to any Honda dealer. If they determine that the cause is clogging of the EGR system, they will repair it at no charge for parts or labor.

**What to do if you feel this notice is in error**

Our records show that you are the current owner of a 1999–01 Accord. If this is not the case, or the name/address information is incorrect, please fill out and return the enclosed, postage-paid *Information Change Card*. We will then update our records.

**If you have questions**

If you have questions about this notice, or feel that you may have paid for a repair that is covered by this warranty extension, please call Honda Automobile Customer Service at (800) 999-1009.