

# Fog Lights

## Circuit Schematic

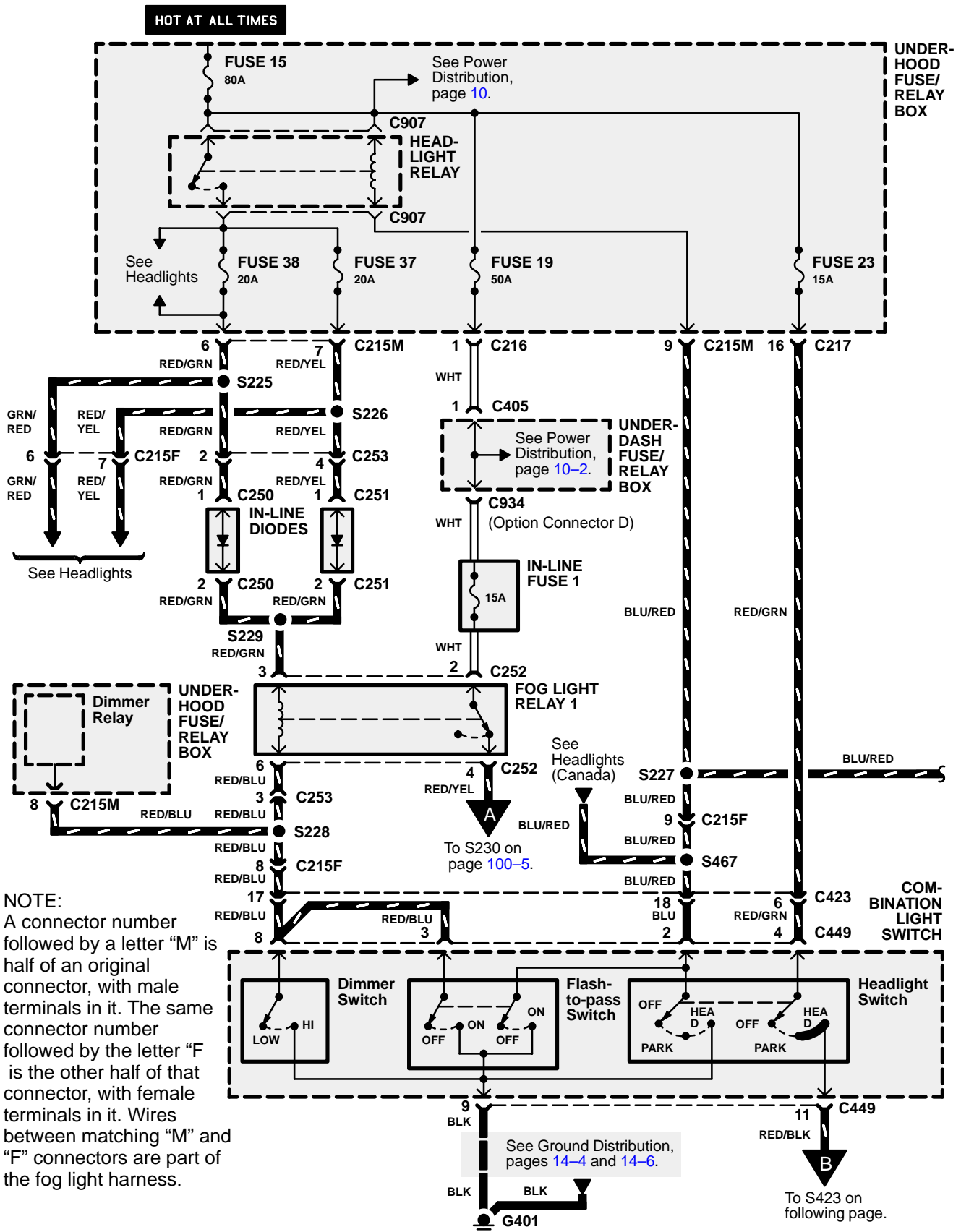

**NOTE:**  
 A connector number followed by a letter "M" is half of an original connector, with male terminals in it. The same connector number followed by the letter "F" is the other half of that connector, with female terminals in it. Wires between matching "M" and "F" connectors are part of the fog light harness.