

220 SERIES, STANDARD HANDLE HIGHEST ACCURACY BORE GAGE 0.000040" (0.001 mm) PRECISION



Maximum Measuring Accuracy

Linear $\leq \pm 0.000040"$ (0.001 mm)
 Repeatability $\leq \pm 0.000010"$ (0.00025 mm)
 Gage R & R capability $\leq 10\%$
 Measuring high tolerance 0.0003" (0.007 mm) bores.

Notable Features

- Highest Accuracy bore gages world wide, linear $\leq 0.000040"$ (0.001 mm) at tolerance range from "Zero" set.
- Highest repeatability world wide $\leq 0.000020"$ (0.0005 mm) unique special segment design.
- Best Gage R & R.

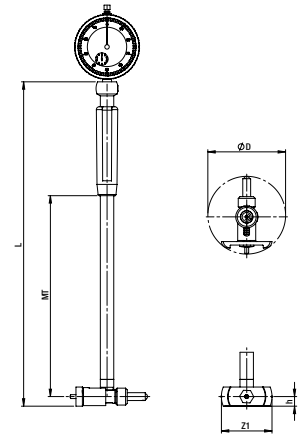

Model 220-035 Gage with fixed measuring pins, increment washers, in box. Order dial indicator separately.



1. Order gage model base or diameter range.
2. Order indicator.
3. Order Master.

Measuring Range Inch (mm)	Z1	Distance from the Bottom "h" Inch (mm)	Contact Point Max. Travel Inch (mm)	Standard Handle Measuring Depth "MT"	Standard Handle Total Measuring Depth "L"	Order No. with Carbide Contacts & Tool Steel Head	Order No. with Ruby Contacts & Tool Steel Head
0.18"-0.24" (4.5-6)	0.15	0.08" (2)	0.013" (0.35)	3.15"	3.15"	220-005	220-305
0.24"-0.31" (6-8)	0.20	0.11" (2.8)	0.019" (0.5)	3.94"	3.94"	220-010	220-310
0.31"-0.47" (8-12)	0.26	0.13" (3.3)	0.027" (0.7)	3.94"	3.94"	220-015	220-315
0.47"-0.79" (12.0-20.0)	0.36	0.18" (4.5)	0.035" (0.9)	4.33"	4.33"	220-020	220-320
0.71"-1.377" (18.0-35.0)	0.58	0.21" (5.4)	0.051" (1.3)	4.33"	8.30"	220-025	220-325
1.37"-2.36" (35.0-60.0)	1.10	0.28" (7.0)	0.051" (1.3)	5.51"	9.53"	220-030	220-330
1.97"-3.94" (50.0-100.0)	1.77	0.34" (8.6)	0.051" (1.3)	7.09"	11.55"	220-035	220-335
1.97"-5.91" (50.0-150.0)	1.77	0.34" (8.6)	0.055" (1.4)	7.09"	11.55"	220-040	220-340
3.94"-6.30" (100.0-160.0)	2.95	0.452" (11.5)	0.063" (1.6)	9.06"	14.34"	220-055	220-355
6.30"-11.02" (160.0-290.0)	4.72	0.47" (12)	0.063" (1.6)	9.06"	14.34"	220-065	220-365
11.02"-16.14" (280.0-410.0)	5.91	0.59" (15)	0.102" (2.6)	15.75"	21.50"	220-070	220-370
11.02"-20.08" (280.0-510.0)	5.91	0.59" (15)	0.102" (2.6)	15.75"	21.50"	220-075	220-375
15.75"-31.50" (400.0-800.0)	11.81	0.59" (15)	0.102" (2.6)	27.56"	33.50"	220-080	220-380

Depth Extensions

For 1.38" (35mm) ranges and up* with 3/8" and 8mm bushing stem.

Extension Length (L) inch	Extension Length (L) mm	Order No. 0.47" Dia.	Order No. 0.71" Dia.	Order No. 0.945" Dia. Carbon Fiber
9.84	250	224-005	—	—
19.69	500	224-010	—	—
29.53	750	224-015	—	—
39.37	1000	224-020	224-120	224-130
59.06	1500	—	224-125	224-135
78.74	2000	—	224-126	224-140

* We recommend using only one depth extension for vertical measurements.



Model 224-010 Depth Extension



Special parallel version

Special right angle version